

Operator's Manual

Hydronic Surface Heater

E 2200

E 3000ES



| | | |
|---------|-----|------|
| 0192779 | 001 | 1210 |
|---------|-----|------|



Copyright notice

© Copyright 2010 by Wacker Neuson Corporation.

All rights, including copying and distribution rights, are reserved.

This publication may be photocopied by the original purchaser of the machine. Any other type of reproduction is prohibited without express written permission from Wacker Neuson Corporation.

Any type of reproduction or distribution not authorized by Wacker Neuson Corporation represents an infringement of valid copyrights. Violators will be prosecuted.

Trademarks

All trademarks referenced in this manual are the property of their respective owners.

Manufacturer

Wacker Neuson Corporation

N92W15000 Anthony Avenue

Menomonee Falls, WI 53051 U.S.A.

Tel: (262) 255-0500 · Fax: (262) 255-0550 · Tel: (800) 770-0957

www.wackerneuson.com

Original instructions

This Operator's Manual presents the original instructions. The original language of this Operator's Manual is American English.

Foreword

Machines covered by this manual

This manual covers machines with the following item numbers:

| Machine | Item Number | Revision |
|------------|-------------|---------------|
| E 2200 | 0620176 | 105 and above |
| E 2200 | 0620215 | 105 and above |
| E 2200G | 0620216 | 110 and above |
| E 2200G | 0620226 | 110 and above |
| E 3000ES | 0620967 | 100 and above |
| E 3000ES-G | 0620968 | 100 and above |

Machine documentation

- Keep a copy of the Operator's Manual with the machine at all times.
- Use the separate Parts Book supplied with the machine to order replacement parts.
- If you are missing any of these documents, please contact Wacker Neuson Corporation to order a replacement or visit www.wackerneuson.com.
- When ordering parts or requesting service information, be prepared to provide the machine model number, item number, revision number, and serial number.

Expectations for information in this manual

- This manual provides information and procedures to safely operate and maintain the above Wacker Neuson model(s). For your own safety and to reduce the risk of injury, carefully read, understand, and observe all instructions described in this manual.
- Wacker Neuson Corporation expressly reserves the right to make technical modifications, even without notice, which improve the performance or safety standards of its machines.
- The information contained in this manual is based on machines manufactured up until the time of publication. Wacker Neuson Corporation reserves the right to change any portion of this information without notice.

Manufacturer's approval

This manual contains references to *approved* parts, attachments, and modifications. The following definitions apply:

- **Approved parts or attachments** are those either manufactured or provided by Wacker Neuson.
- **Approved modifications** are those performed by an authorized Wacker Neuson service center according to written instructions published by Wacker Neuson.
- **Unapproved parts, attachments, and modifications** are those that do not meet the approved criteria.

Unapproved parts, attachments, or modifications may have the following consequences:

- Serious injury hazards to the operator and persons in the work area
- Permanent damage to the machine which will not be covered under warranty

Contact your Wacker Neuson dealer immediately if you have questions about approved or unapproved parts, attachments, or modifications.

| | |
|---|-----------|
| Foreword | 3 |
| 1 Safety Information | 9 |
| 1.1 Signal Words Used in this Manual | 9 |
| 1.2 Machine Description and Intended Use | 10 |
| 1.3 Safety Guidelines for Operating the Machine | 11 |
| 1.4 Service Safety | 13 |
| 1.5 Safety Guidelines for Operating Combustion Burners | 15 |
| 1.6 Safety Guidelines for Operating Gensets | 16 |
| 1.7 Safety Guidelines for Towing the Machine | 18 |
| 2 Labels | 20 |
| 2.1 Label Locations | 20 |
| 2.2 Label Meanings | 22 |
| 3 Lifting and Transporting | 27 |
| 3.1 Lifting the Machine | 27 |
| 3.2 Preparing the Machine for Transport on a Truck or Trailer | 28 |
| 3.3 Before Towing Checklist | 29 |
| 4 Operation | 30 |
| 4.1 Control / Component Locations | 30 |
| 4.2 Control / Component Descriptions | 31 |
| 4.3 Control Panel | 32 |
| 4.4 Control Panel Components | 33 |
| 4.5 Pumps, Gauges, and Valves | 34 |
| 4.6 Preparing the Machine for First Use | 35 |
| 4.7 General Sequence of Operation | 36 |
| 4.8 Recommended Fuel | 37 |
| 4.9 Positioning the Machine | 38 |
| 4.10 Pre-Starting Checks | 40 |
| 4.11 Connecting Power to the Machine | 42 |
| 4.12 Starting and Stopping the Generator | 43 |
| 4.13 Preheating the HTF | 44 |
| 4.14 Initiating HTF Flow | 45 |
| 4.15 Setting the Operating Temperature | 47 |
| 4.16 Positioning the Hoses and Operating the Machine | 48 |
| 4.17 Monitoring the Operating Parameters | 50 |

| | | |
|----------|--|-----------|
| 4.18 | Stopping the Machine Temporarily | 51 |
| 4.19 | Rewinding the Hoses | 52 |
| 4.20 | Shutting Down and Packing Up the Machine | 54 |
| 4.21 | Resetting a Low HTF Level Fault | 55 |
| 4.22 | Quick-Connect Coupling Usage and Care | 58 |
| 4.23 | Resetting the Snap Switch | 59 |
| 4.24 | Burner Controller Periods and Modes | 60 |
| 5 | Accessories | 65 |
| 5.1 | Available Accessories | 65 |
| 5.2 | Connecting the HX 200 or HX 60 HEAT XCHANGER™ | 66 |
| 5.3 | Connecting the HX 100 or HX 30 HEAT XCHANGER™ | 68 |
| 5.4 | Connecting the HX 50 or HX 15 HEAT XCHANGER™ | 70 |
| 5.5 | Combining the Machine with One HHS and One DPP | 72 |
| 5.6 | Combining the Machine with Two HHS and Two DPP (E 2200 only) . | 74 |
| 5.7 | Mounting the Auxiliary Pump Panel | 76 |
| 6 | Burner Setup | 77 |
| 6.1 | Adjusting the Burner Electrodes | 80 |
| 6.2 | Replacing the Burner Nozzle | 83 |
| 6.3 | Setting the “Z” Distance on V1-Style Heads | 86 |
| 6.4 | Adjusting the Air Settings | 88 |
| 6.5 | Setting the Fuel Pressure | 89 |
| 7 | Maintenance | 91 |
| 7.1 | Periodic Maintenance Schedule | 91 |
| 7.2 | Repairing a Hose | 92 |
| 7.3 | Inspecting the HTF System and the Fuel System | 94 |
| 7.4 | Inspecting Electrical Cords | 95 |
| 7.5 | Filling the HTF Reservoir | 96 |
| 7.6 | Cleaning the HTF Strainer | 98 |
| 7.7 | Replacing the Fuel Filter | 100 |
| 7.8 | Lubricating the Hose Reel System | 101 |
| 7.9 | Cleaning the Turbulators and the Exhaust Ducting | 102 |
| 7.10 | Inspecting/Replacing the Rope Gasket | 104 |
| 7.11 | Storing the Machine | 105 |
| 7.12 | Preparing the Machine for Seasonal Operation | 106 |

| | | |
|-----------|---------------------------------------|------------|
| 8 | Troubleshooting | 108 |
| 8.1 | Troubleshooting the Machine | 108 |
| 9 | Technical Data | 110 |
| 9.1 | E 2200 | 110 |
| 9.2 | E 3000ES | 111 |
| 9.3 | Trailer | 112 |
| 9.4 | Dimensions | 113 |
| | MSDS: Dowfrost™ HD 50 | 114 |
| | Fuji Temperature Controller | 121 |
| 10 | Schematics | 124 |
| 10.1 | Electrical Schematic | 124 |
| 10.2 | Electrical Schematic Components | 125 |
| 10.3 | Burner System Circuit | 128 |
| 10.4 | Circulation System Circuit | 129 |
| 10.5 | Rewind System Circuit | 130 |

1 Safety Information

1.1 Signal Words Used in this Manual

This manual contains DANGER, WARNING, CAUTION, *NOTICE*, and NOTE signal words which must be followed to reduce the possibility of personal injury, damage to the equipment, or improper service.



This is the safety alert symbol. It is used to alert you to potential personal hazards.
▶ Obey all safety messages that follow this symbol.



DANGER

DANGER indicates a hazardous situation which, if not avoided, will result in death or serious injury.

- ▶ To avoid death or serious injury from this type of hazard, obey all safety messages that follow this signal word.



WARNING

WARNING indicates a hazardous situation which, if not avoided, could result in death or serious injury.

- ▶ To avoid possible death or serious injury from this type of hazard, obey all safety messages that follow this signal word.



CAUTION

CAUTION indicates a hazardous situation which, if not avoided, could result in minor or moderate injury.

- ▶ To avoid possible minor or moderate injury from this type of hazard, obey all safety messages that follow this signal word.

NOTICE: Used without the safety alert symbol, NOTICE indicates a situation which, if not avoided, could result in property damage.

Note: A Note contains additional information important to a procedure.

1.2 Machine Description and Intended Use

This machine is a hydronic surface heater. The Wacker Neuson Hydronic Surface Heaters consist of trailer-mounted enclosures that house an optional diesel generator, a hydronic heater, electric motors, fixed pump(s) and plumbing, a diesel (or gas) burner, a fuel tank, and a hose handling system.

The hydronic heating system utilizes a burner that indirectly warms the Heat Transfer Fluid (HTF). The warmed HTF is continuously circulated through a vented, closed loop hose system. A positive displacement pump pushes the warmed HTF through the hose system, thereby radiating and transferring the heat to the required application area.

An insulated blanket may be laid over the hoses to increase efficiency. The low HTF level protection device shuts down the machine if the HTF level drops below minimum operational capacity.

This machine is intended to be used as a surface heater in order to thaw frozen ground, to cure concrete, or to prevent frost and freezing. In addition, when used with other Wacker Neuson accessories, this machine can be used to heat air.

This machine has been designed and built strictly for the intended use(s) described above. Using the machine for any other purpose could permanently damage the machine or seriously injure the operator or other persons in the area. Machine damage caused by misuse is not covered under warranty.

The following are some examples of misuse:

- Using the machine to heat anything other than what is stated above
- Using the machine to pump anything other than the factory recommended heat transfer fluid
- Using the generator (if equipped) to power anything other than the machine itself or Wacker Neuson accessory machines as instructed in the Operator's Manual
- Using the machine as a ladder, support, or work surface
- Using the machine to carry or transport passengers or equipment
- Using the machine to tow other machines
- Operating the generator (if equipped) in a manner that is inconsistent with all federal, state, and local codes and regulations
- Operating the machine outside of factory specifications
- Operating the machine in a manner inconsistent with all warnings found on the machine and in the Operator's Manual

This machine has been designed and built in accordance with the latest global safety standards. It has been carefully engineered to eliminate hazards as far as practicable and to increase operator safety through protective guards and labeling. However, some risks may remain even after protective measures have been taken. They are called residual risks. On this machine, they may include exposure to:

- Heat, noise, and exhaust from the engine or hydronic heater
- Burns from HTF or radiant heat from the hoses
- Fire hazards from improper refueling techniques
- Fuel and its fumes

- Personal injury from improper lifting of the trailer tongue
- Tripping hazards from the hoses

To protect yourself and others, make sure you thoroughly read and understand the safety information presented in this manual before operating the machine.

1.3 Safety Guidelines for Operating the Machine

Operator training

Before operating the machine:

- Read and understand the operating instructions contained in all manuals delivered with the machine.
- Familiarize yourself with the location and proper use of all controls and safety devices.
- Contact Wacker Neuson Corporation for additional training if necessary.

When operating this machine:

- Do not allow improperly trained people to operate the machine. People operating the machine must be familiar with the potential risks and hazards associated with it.

Operator qualifications

Only trained personnel are permitted to start, operate, and shut down the machine. They also must meet the following qualifications:

- have received instruction on how to properly use the machine
- are familiar with required safety devices

The machine must not be accessed or operated by:

- children
- people impaired by alcohol or drugs

Application area

Be aware of the application area.

- Keep unauthorized personnel, children, and pets away from the machine.
- Remain aware of changing positions and the movement of other equipment and personnel in the application area/job site.

Be aware of the application area.

- Do not operate the machine in areas that contain flammable objects, fuels, or products that produce flammable vapors.

Safety devices, controls, and attachments

Only operate the machine when:

- All safety devices and guards are in place and in working order.
- All controls operate correctly.
- The machine is set up correctly according to the instructions in the Operator's Manual.
- The machine is clean.
- The machine's labels are legible.

To ensure safe operation of the machine:

- Do not operate the machine if any safety devices or guards are missing or inoperative.
 - Do not modify or defeat the safety devices.
 - Only use accessories or attachments that are approved by Wacker Neuson Corporation.
-

Safe operating practices

When operating this machine:

- Remain aware of the machine's moving parts. Keep hands, feet, and loose clothing away from the machine's moving parts.

When operating this machine:

- Do not operate a machine in need of repair.
-

Personal Protective Equipment (PPE)

Wear the following Personal Protective Equipment (PPE) while operating this machine:

- Close-fitting work clothes that do not hinder movement
- Safety glasses with side shields
- Hearing protection
- Safety-toed footwear

1.4 Service Safety

Service training

Before servicing or maintaining the machine:

- Read and understand the instructions contained in all manuals delivered with the machine.
- Familiarize yourself with the location and proper use of all controls and safety devices.
- Only trained personnel shall troubleshoot or repair problems occurring with the machine.
- Contact Wacker Neuson Corporation for additional training if necessary.

When servicing or maintaining this machine:

- Do not allow improperly trained people to service or maintain the machine. Personnel servicing or maintaining the machine must be familiar with the associated potential risks and hazards.

Precautions

Follow the precautions below when servicing or maintaining the machine.

- Read and understand the service procedures before performing any service to the machine.
- All adjustments and repairs must be completed before operation. Do not operate the machine with a known problem or deficiency.
- All repairs and adjustments shall be completed by a qualified technician.
- Turn off the machine before performing maintenance or making repairs.
- Remain aware of the machine's moving parts. Keep hands, feet, and loose clothing away from the machine's moving parts.
- Reinstall the safety devices and guards after repair and maintenance procedures are complete.

Machine modifications

When servicing or maintaining the machine:

- Use only accessories/attachments that are approved by Wacker Neuson Corporation.

When servicing or maintaining the machine:

- Do not defeat safety devices.
- Do not modify the machine without the express written approval of Wacker Neuson Corporation.

Replacing parts and labels

- Replace worn or damaged components.
- Replace all missing and hard-to-read labels.
- When replacing electrical components, use components that are identical in rating and performance as the original components.
- When replacement parts are required for this machine, use only Wacker Neuson replacement parts or those parts equivalent to the original in all types of specifications, such as physical dimensions, type, strength, and material.

Lifting and transporting

When lifting the machine:

- Make sure slings, chains, hooks, ramps, jacks, and other types of lifting devices are attached securely and have enough weight-bearing capacity to lift or hold the machine safely. See chapter *Technical Data*.
- Remain aware of the location of other people when lifting the machine.
- Make sure the transporting vehicle has sufficient load capacity and platform size to safely transport the machine. See chapter *Technical Data*.

To reduce the possibility of injury:

- Do not stand under the machine while it is being lifted or moved.
 - Do not get onto the machine while it is being lifted or moved.
-

Cleaning

When cleaning and servicing the machine:

- Keep the machine clean and free of debris such as leaves, paper, cartons, etc.
- Keep the labels legible.

When cleaning the machine:

- Do not clean the machine while it is running.
 - Never use gasoline or other types of fuels or flammable solvents to clean the machine. Fumes from fuels and solvents can become explosive.
-

Personal Protective Equipment (PPE)

Wear the following Personal Protective Equipment (PPE) while servicing or maintaining this machine:

- Close-fitting work clothes that do not hinder movement
- Safety glasses with side shields
- Hearing protection
- Safety-toed footwear

In addition, before servicing or maintaining the machine:

- Tie back long hair.
- Remove all jewelry (including rings).

1.5 Safety Guidelines for Operating Combustion Burners

When using the machine:

- Clean up any spilled fuel immediately.
- Replace the fuel tank cap after refueling the machine.
- Refill the fuel tank in a well-ventilated area.
- Shut down the generator, if equipped, when refueling.

When using the machine:



DANGER

Exhaust gas from the burner contains carbon monoxide, a deadly poison. Exposure to carbon monoxide can kill you in minutes.

- ▶ Never run the machine indoors or in an enclosed area unless the machine is vented properly.
-
- Do not fill or drain the fuel tank near an open flame or while the machine is running.
 - Do not smoke when refueling the machine.

1.6 Safety Guidelines for Operating Gensets

**DANGER**

- ▶ **Carbon monoxide.** Using a generator indoors CAN KILL YOU IN MINUTES. Generator exhaust contains carbon monoxide (CO). This is a poison you cannot see or smell. If you can smell the generator exhaust, you are breathing CO. But even if you cannot smell the exhaust, you could be breathing CO.

**WARNING**

- Electrocution hazard. Generators present special hazards during operation and servicing. These include the risk of electrocution or severe electrical shock. Failure to follow the safety information below can result in severe injury or death.
- ▶ Read and follow the safety instructions in this Operator's Manual.
 - ▶ Contact the genset manufacturer for additional information regarding the genset.

**WARNING**

- Internal combustion engines present special hazards during operation and fueling. Failure to follow the warnings and safety instructions could result in severe injury or death.
- ▶ Read and follow the safety instructions in this Operator's Manual.
 - ▶ Contact the genset manufacturer for additional information regarding the genset.

This machine is built with user safety in mind; however, like any electrical device it can present serious hazards if improperly operated and serviced. Follow instructions carefully. Should questions arise during operation or service of this equipment, contact your Wacker Neuson dealer.

Before operating the genset

- Know how to start, operate, and stop the genset before starting it.
- Obtain the proper training for operating the genset. Do not allow untrained personnel to operate or service the genset.
- Check the fuel lines and the fuel tank for leaks and cracks before starting the engine.
- Clean the genset of any spilled fuel.

Running the genset

- Do not start the engine if fuel has spilled or a fuel odor is present.
- Keep the area around the exhaust pipe free of flammable materials.
- Do not smoke while operating the genset.
- Keep sparks, flames, electrical arcs, and other sources of ignition far away from the genset.
- Do not touch the engine or muffler while the engine is running or immediately after it has been turned off.
- Do not operate a machine when its fuel cap is loose or missing.

- Do not overload the genset. The total amperage of the tools and equipment attached to the genset must not exceed the load rating of the genset.
 - Do not operate the genset with wet hands.
 - Do not remove the radiator cap when the genset is running or is hot.
-

Refueling safety

When adding fuel to the fuel tank:

- Do not smoke.
- Do not refuel a hot or running engine.

When adding fuel to the fuel tank:

- Keep sparks, flames, electrical arcs, and other sources of ignition far away from the genset.
 - Refill the fuel tank only in a well-ventilated area.
 - Reinstall the fuel tank cap after refueling.
-

Maintenance guidelines

- Only a trained technician should attempt to repair the genset.
- Test procedures which require that the generator be running must be performed using extreme caution.
- Make sure clothing and shoes are dry, stand on a dry wooden platform or rubber insulating mat, and use tools with insulated handles when servicing the genset.
- Engine antifreeze is toxic to humans and animals. Clean up spills and dispose of used engine antifreeze in accordance with local environmental regulations.

1.7 Safety Guidelines for Towing the Machine

**WARNING**

Risk of severe injury or death. Improper trailer condition and towing technique can lead to an accident.

- ▶ Obey the trailer manufacturer's instructions and the instructions below to reduce the risk of an accident.

When towing the machine:

- Do not tow the machine if the towing vehicle's hitch or the trailer's coupler are damaged.
- Do not tow the machine if any of the trailer's lug nuts are missing.
- Do not tow the machine if the trailer's tires have less than 1.5 mm (1/16 inch) of tread.
- Do not tow the machine unless the trailer's brakes are functioning properly.
- Do not exceed the trailer manufacturer's speed limitations.

When towing the machine:

- Only tow the machine when the trailer's lug nuts are properly torqued.
- Only tow the machine when the trailer's tires are properly inflated.
- Only tow the machine when all trailer lights are functioning correctly.
- Only tow the machine when the trailer's safety chains are connected to the towing vehicle in a crisscross pattern.
- Maintain extra distance between the towing vehicle and other vehicles.
- Avoid soft shoulders, curbs, and sudden lane changes.
- Abide by all licensing requirements for your area.

If you have not driven a towing vehicle with trailer before, practice turning, stopping, and backing up the towing vehicle with trailer in an area away from traffic. Only drive the towing vehicle with trailer when you are confident in your ability to do so.

Notes

2 Labels

2.1 Label Locations

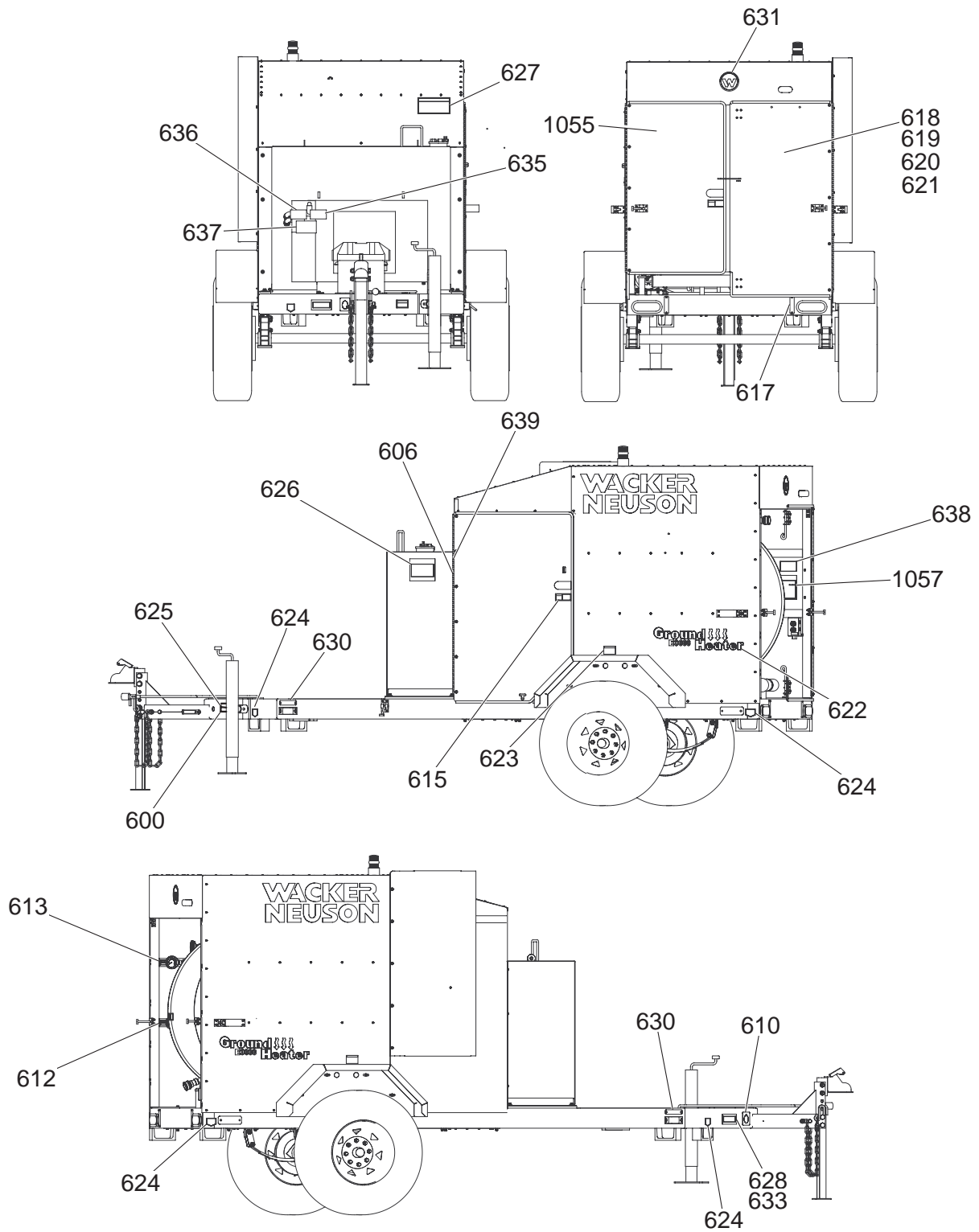

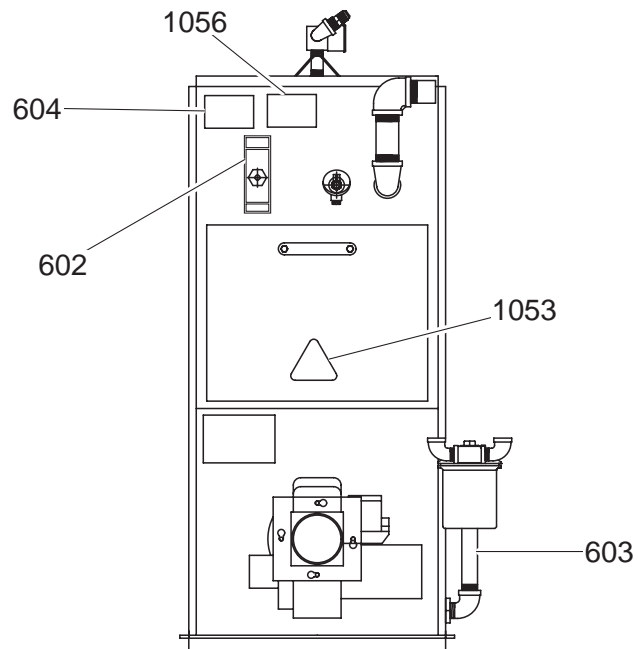
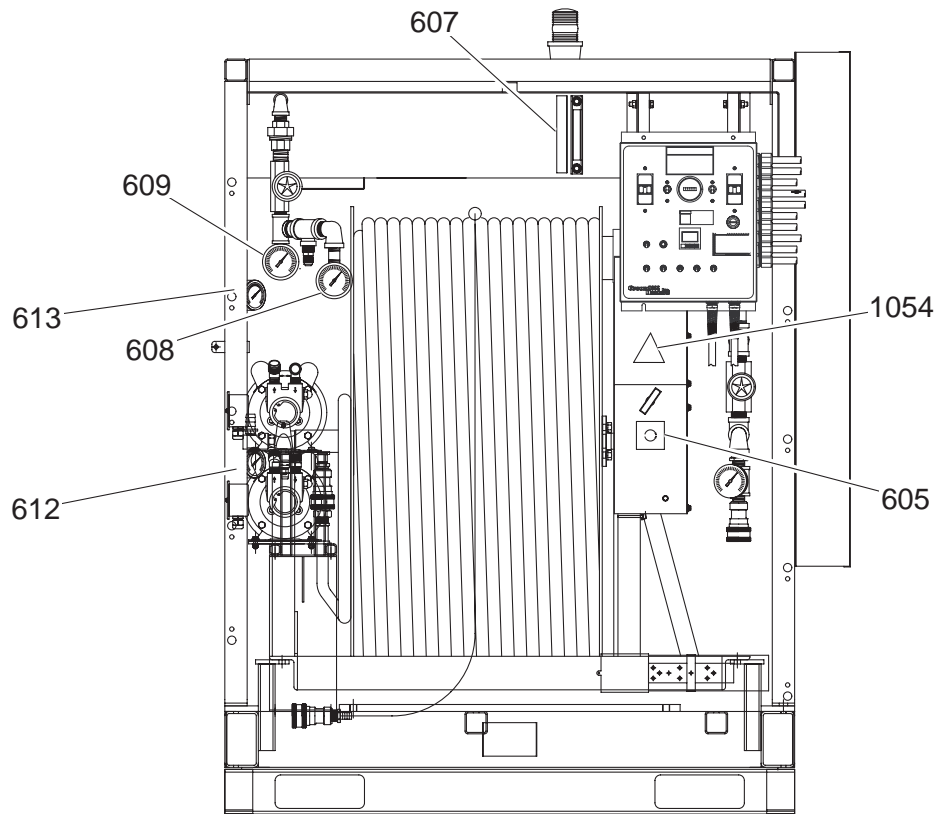

wc_gr008049





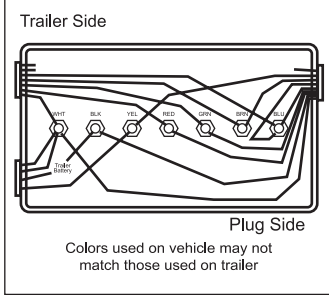
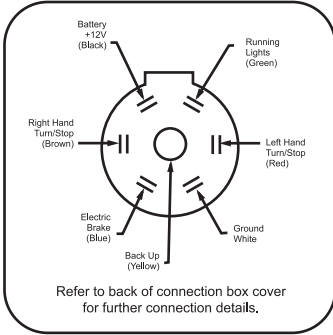
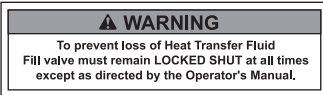

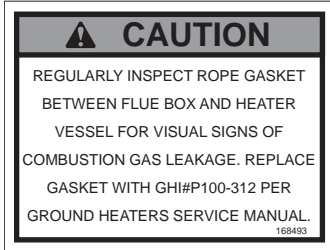
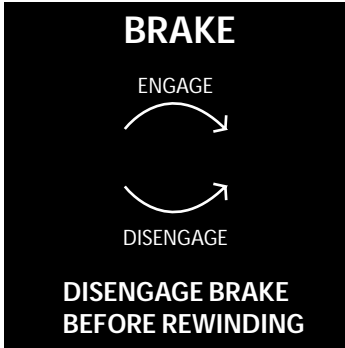
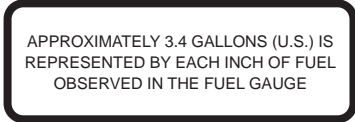



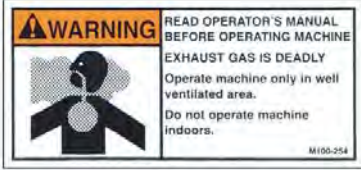

wc_gr008050

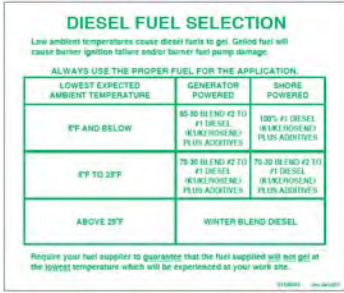

2.2 Label Meanings

| | | |
|------------|---|--|
| <p>600</p> |  | <p>—</p> |
| <p>601</p> |  | <p>Refer to back of connection box for further connection details.</p> |
| <p>602</p> | | <p>Stop! Do not reset (until HTF leak is repaired and HTF level is restored) Red “LOW LEVEL FAULT” light on control panel indicates HTF is below the minimum operating level. Follow procedure below to rectify the fault: 1. Shut off burner switch and pump switch(es). 2. Find and repair the HTF leak. 3. Add HTF to reservoir up to “MIN” level on HTF sight gauge. 4. Press manual reset button (below). 5. Turn on burner switch. 6. After burner ignites, turn on pump(s) one at a time.</p> |
| <p>603</p> |  | <p>To prevent loss of Heat Transfer Fluid, the fill valve must remain LOCKED SHUT (closed) at all times except as directed in the Operator's Manual.</p> |

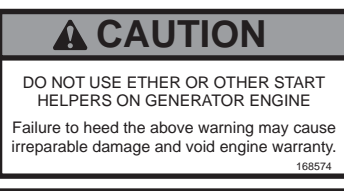
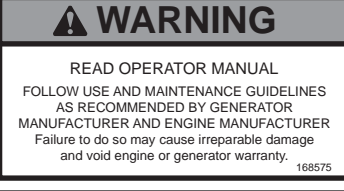
| | | |
|------------|---|--|
| <p>604</p> |  | <p>Regularly inspect the rope gasket located between the flue box and the heater vessel for visual signs of combustion gas leakage. Replace the gasket with part number P100-312 when needed per the service manual.</p> |
| <p>605</p> |  | <p>—</p> |
| <p>606</p> |  | <p>Approximately 3.4 gallons (U.S.) is represented by each inch of fuel observed in the fuel gauge.</p> |
| <p>607</p> |  | <p>Heat Transfer Fluid level. This label indicates the minimum and maximum level for the Heat Transfer Fluid. This label is located adjacent to a sight gauge on the Heat Transfer Fluid reservoir.</p> |
| <p>610</p> |  | <p>Plug in the strobe light to this side of the receptacle.</p> |

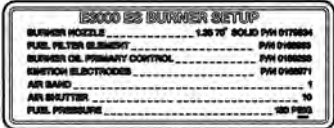
| | | |
|-----|---|--|
| 611 |  | <p>Plug in the Pump Pack to this side of the receptacle.</p> |
| 614 |  | <p>—</p> |
| 615 |  | <p>WARNING: Read Operator's Manual before operating machine. Exhaust gas is deadly. Operate machine only in well ventilated area. Do not operate machine indoors.</p> |
| 623 |  | <p>WARNING: Lugnuts factory torqued to 110 ft.lbs. Verify lugnuts are properly torqued before transporting. Failure to heed above warning could result in wheel loss which can cause injury or death.</p> |
| 624 |  | <p>Tie-down location marker.</p> |
| 625 |  | <p>WARNING! Jack should not be deployed for truck bed transport. Properly support tongue with wood block and retract jack before tightening chains or straps. Jack is not designed to take loads that ratcheting straps or load binded chains can deliver. Use jack for raising or lowering trailer tongue only. Failure to heed these warnings could result in damage to personal property or cause serious injury or death.</p> |

| 626 |  <p>DIESEL FUEL SELECTION Low ambient temperatures cause diesel fuels to gel. Gelled fuel will cause burner ignition failure and/or burner fuel pump damage.</p> <p>ALWAYS USE THE PROPER FUEL FOR THE APPLICATION.</p> <table border="1"> <thead> <tr> <th>LOWEST EXPECTED AMBIENT TEMPERATURE</th> <th>GENERATOR POWERED</th> <th>SHORE POWERED</th> </tr> </thead> <tbody> <tr> <td>37°F AND BELOW</td> <td>85:15 BLEND #2 TO #1 DIESEL (INCLUDES MONITOR PLUS ADDITIVES)</td> <td>100% #1 DIESEL (INCLUDES MONITOR PLUS ADDITIVES)</td> </tr> <tr> <td>37°F TO 28°F</td> <td>75:25 BLEND #2 TO #1 DIESEL (INCLUDES MONITOR PLUS ADDITIVES)</td> <td>75:25 BLEND #2 TO #1 DIESEL (INCLUDES MONITOR PLUS ADDITIVES)</td> </tr> <tr> <td>ABOVE 28°F</td> <td colspan="2">WINTER BLEND DIESEL</td> </tr> </tbody> </table> <p>Require your fuel supplier to guarantee that the fuel supplied will not gel at the lowest temperature which will be experienced at your work site.</p> | LOWEST EXPECTED AMBIENT TEMPERATURE | GENERATOR POWERED | SHORE POWERED | 37°F AND BELOW | 85:15 BLEND #2 TO #1 DIESEL (INCLUDES MONITOR PLUS ADDITIVES) | 100% #1 DIESEL (INCLUDES MONITOR PLUS ADDITIVES) | 37°F TO 28°F | 75:25 BLEND #2 TO #1 DIESEL (INCLUDES MONITOR PLUS ADDITIVES) | 75:25 BLEND #2 TO #1 DIESEL (INCLUDES MONITOR PLUS ADDITIVES) | ABOVE 28°F | WINTER BLEND DIESEL | | <p>Fuel blend guide: This label indicates the proper fuel blending requirements based upon power source and ambient temperature ranges. Consult the Operator's Manual for more information.</p> |
|-------------------------------------|--|--|-------------------|---------------|----------------|---|--|--------------|---|---|------------|---------------------|--|---|
| LOWEST EXPECTED AMBIENT TEMPERATURE | GENERATOR POWERED | SHORE POWERED | | | | | | | | | | | | |
| 37°F AND BELOW | 85:15 BLEND #2 TO #1 DIESEL (INCLUDES MONITOR PLUS ADDITIVES) | 100% #1 DIESEL (INCLUDES MONITOR PLUS ADDITIVES) | | | | | | | | | | | | |
| 37°F TO 28°F | 75:25 BLEND #2 TO #1 DIESEL (INCLUDES MONITOR PLUS ADDITIVES) | 75:25 BLEND #2 TO #1 DIESEL (INCLUDES MONITOR PLUS ADDITIVES) | | | | | | | | | | | | |
| ABOVE 28°F | WINTER BLEND DIESEL | | | | | | | | | | | | | |
| 627 |  <p>WARNING Attach Chains or Straps ONLY to Axles and Designated "TIE DOWN" Points Never Run Straps Across Any Surface on this Machine Which is Painted RED. Failure to heed above warning could result in damage to personal property or cause serious injury or death.</p> | <p>WARNING: Attach chains or straps only to axles and designated "tie-down" points. Never run straps across any surface on this machine which is painted red. Failure to heed above warning could result in damage to personal property or cause serious injury or death.</p> | | | | | | | | | | | | |
| 635 |  <p>CAUTION DO NOT USE ETHER OR OTHER START HELPERS ON GENERATOR ENGINE Failure to heed the above warning may cause irreparable damage and void engine warranty.</p> | <p>Do not use ether or other start helpers on generator engine. Failure to heed the above warning may cause irreparable damage and void engine warranty.</p> | | | | | | | | | | | | |
| 636 |  <p>WARNING READ OPERATOR MANUAL FOLLOW USE AND MAINTENANCE GUIDELINES AS RECOMMENDED BY GENERATOR MANUFACTURER AND ENGINE MANUFACTURER Failure to do so may cause irreparable damage and void engine or generator warranty.</p> | <p>Read Operator's Manual. Follow use and maintenance guidelines as recommended by generator manufacturer and engine manufacturer. Failure to do so may cause irreparable damage and void engine or generator warranty.</p> | | | | | | | | | | | | |
| 637 |  <p>WARNING Attach Chains or Straps ONLY to Axles and Designed "TIE DOWN" Points Never Run Straps Across Any Surface on this Machine Which is Painted RED. Failure to heed above warning could result in damage to personal property or cause serious injury or death.</p> | <p>Attach chains or straps only to axles and designated "TIE DOWN" points. Never run straps across any surface on this machine which is painted red. Failure to heed above warning could result in damage to personal property or cause serious injury or death.</p> | | | | | | | | | | | | |
| 639 |  <p>E2200 ES BURNER SETUP</p> <ul style="list-style-type: none"> BURNER NOZZLE 1.25" 70° SOLID P/N 017884 FUEL FILTER ELEMENT P/N 018859 BURNER OIL PRIMARY CONTROL P/N 018859 SWITCH ELECTRODES P/N 018871 AIR DAMP 1 FUEL PRESSURE 100 PSIG | <p>Burner setup. This label indicates important setup information for the burner.</p> | | | | | | | | | | | | |

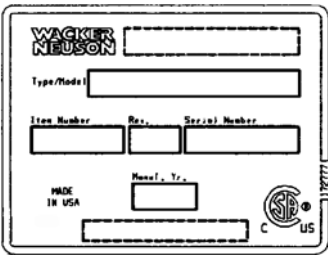
| | | |
|------|--|---|
| | | |
| 1053 |  | <p>CAUTION! Hot surface hazard!</p> |
| 1054 |  | <p>WARNING! Hand entanglement hazard! Moving parts can crush and cut. Do not operate with guard removed.</p> |
| 1055 |  | <p>HTF MSDS label. This label is the Material Safety Data Sheet for the HTF installed in the factory.</p> |
| 1056 | <div style="border: 1px solid black; padding: 10px; text-align: center;"> <p>THIS HEATER OPERATES AT ZERO (ATMOSPHERIC) PRESSURE AND IS NOT SUBJECT TO REGULATIONS APPLICABLE TO PRESSURIZED "BOILERS"</p> </div> | <p>—</p> |
| XX |  | <p>A nameplate listing the model number, item number, revision number, and serial number is attached to each unit. Please record the information found on this plate so it will be available should the nameplate become lost or damaged. When ordering parts or requesting service information, you will always be asked to specify the model number, item number, revision number, and serial number of the unit.</p> |

3 Lifting and Transporting

3.1 Lifting the Machine

- Requirements**
- Lifting device (crane or hoist) capable of supporting the machine's weight
 - Lifting hooks and chains capable of supporting the machine's weight
 - Machine stopped, cooled, and accessories removed. See section *Shutting Down and Packing Up the Machine*.



WARNING

Crushing hazard. You may be crushed if the lifting devices fail.

- ▶ Never stand under, or get onto, the machine while it is being lifted or moved.
 - ▶ Use only the designated lifting points to lift the machine.
-

Procedure Perform the procedure below to lift the machine.

1. Only those machines fitted with optional lifting bails may be lifted with a crane. Attach the lifting hook and chain from the crane to one of the lifting eyes (**a**) on the machine.

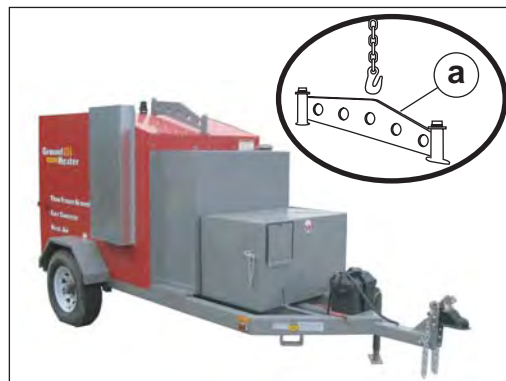

wc_gr008053

2. Lift the machine a short distance.
3. Check for stability. If necessary, lower the machine and reposition it. Only continue lifting when the machine is stable.
4. Continue lifting the machine as necessary.

3.2 Preparing the Machine for Transport on a Truck or Trailer

- Requirements**
- Machine stopped. See topic *Shutting Down and Packing Up the Machine*.
 - Flatbed truck or trailer capable of supporting the machine's weight.
 - Chains, hooks, or straps capable of supporting the machine's weight.



WARNING

Crushing hazard. Improperly securing the machine can lead to a crushing hazard.

- ▶ Use only the designated tie-down points to secure the machine to a truck or trailer.
-

Checklist

Before transporting the machine, check the following items:

Machine

- Check that the hoses are completely wound on the hose reel and that all hose ends are secured.
- Check that all accessories are securely stored within the machine.
- Check that all doors and access panels of the machine are closed.
- Check that all electrical supplies are disconnected from the machine.
- For machines with external fuel supplies, check that all fuel supplies are disconnected from the machine.

Loading and transporting equipment

- Check that the transport vehicle or trailer can support the weight of the machine.
- Check that the transport vehicle or trailer is wide enough to support the machine.
- Check that the wheels of the transport vehicle or trailer are chocked during the loading process.
- Check that the transport vehicle or trailer is clean and free of grease, oil, ice, and other loose material.
- If the machine is mounted to a trailer, check that a transport block (piece of wood or other similar material) is available to support the trailer tongue during transporting. Do not use the machine's jack stand to support the trailer tongue during transporting.
- Check that any ramps used in the loading process:
 - Can support the weight of the machine
 - Are clean and free of grease, oil, ice, and other loose material.
 - Are securely connected to the transport vehicle or trailer.
 - Are of sufficient length to keep the loading angle 15° or less.

In addition:

- Check that the loading area is flat and the ground is stable.
- Check the overall height of the machine once loaded. Plan your travel route so there will be adequate clearance for overpasses, road signs, buildings, etc.
- Check local regulations regarding transporting and obey these regulations.

3.3 Before Towing Checklist

Before towing the machine, check the licensing requirements for trailers in your area. Also check the following items:

Hitch and coupler

- Check that the towing vehicle and hitch have a rating equal to or greater than the GVWR of the machine. See *Technical Data*.
- Check that the hitch of the towing vehicle and coupler of the trailer are compatible.
- Check the condition of both the coupler and hitch.
- Check that all fasteners on the coupler are secure.
- Check that the coupler has fresh grease applied to it.

Wheels

- Check that all lug nuts are in place and are properly torqued.
- Check the tread wear of the tires.
- Check that the tires are inflated to the proper pressure.

Trailer operation

- Check that the directional and running lights on the trailer function correctly.
- Check that the safety chains of the trailer are connected to the towing vehicle using a crisscross pattern.
- Check that the trailer's breakaway cable is attached to the towing vehicle.
- Check the operation of the trailer brakes by braking the towing vehicle at a slow speed. Both the vehicle and the trailer must brake smoothly. If the trailer pushes, check the fluid level in the surge brakes or the operation of the electric brakes.

4 Operation

4.1 Control / Component Locations

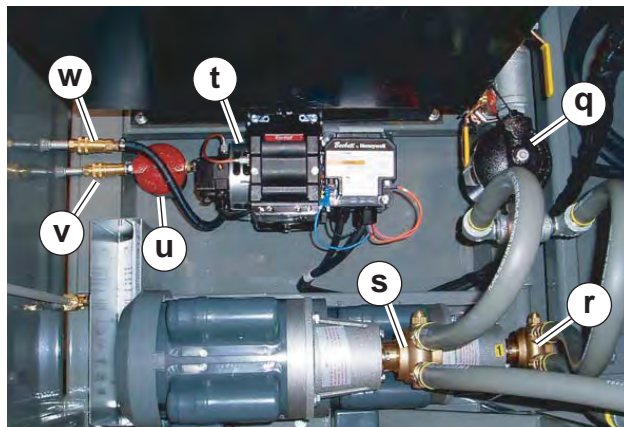
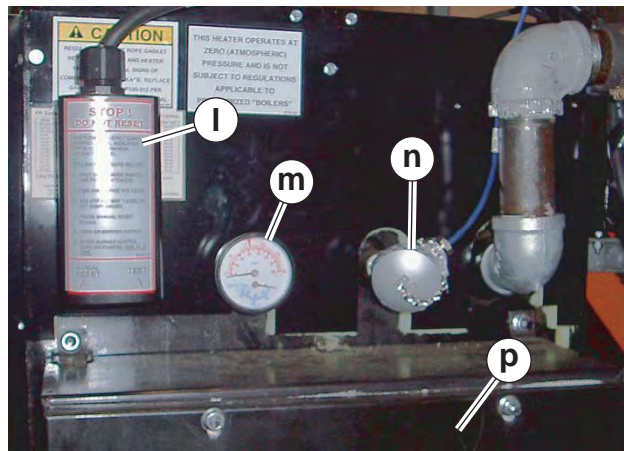

wc_gr008060

4.2 Control / Component Descriptions

| Ref. | Description | Ref. | Description |
|------|-------------------------|------|----------------------------|
| a | Lifting bail (optional) | l | Low-level shut-down device |
| b | Strobe light | m | Temperature/pressure gauge |
| c | Tie-down bracket | n | Thermocouple |
| d | Exhaust stack | p | Hydronic heater flue box |
| e | Reflector | q | HTF filter |
| f | Battery | r | Pump 1 |
| g | Jack stand | s | Pump 2 |
| h | Trailer chains | t | Burner |
| i | Trailer hitch | u | Fuel filter |
| j | Generator (optional) | v | Fuel supply line |
| k | Fuel tank | w | Fuel return line |

4.3 Control Panel

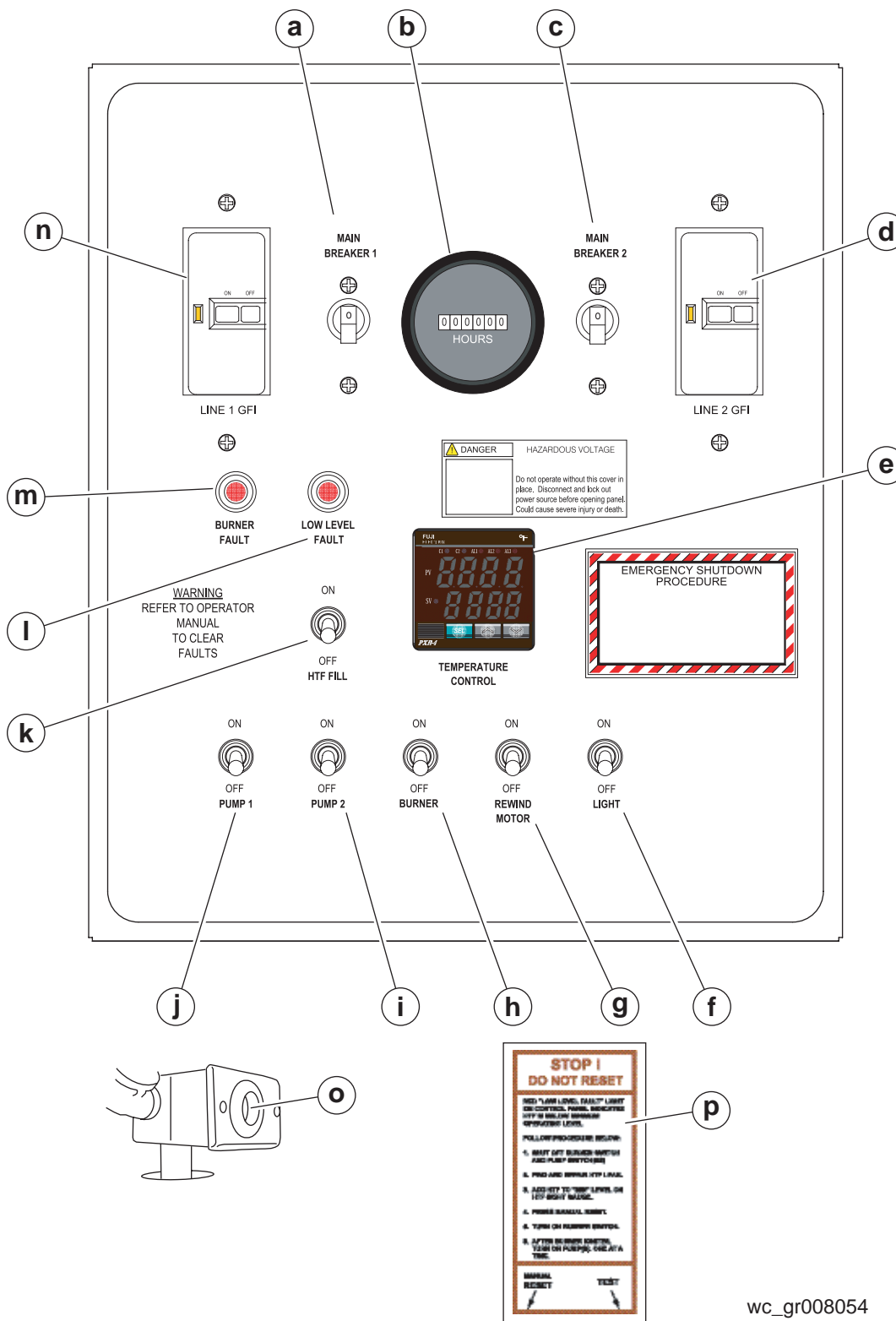

wc_gr008054

4.4 Control Panel Components

| Ref | Description | Function |
|-----|---|--|
| a | Circuit breaker 1 | Controls power to the control circuit (20A) |
| b | Hour meter | Meters usage of the machine. |
| c | Circuit breaker 2 | Controls power to the pump circuit (20A) |
| d | Line 2 GFCI | Provides protection for the operator. |
| e | Temperature controller | <ul style="list-style-type: none"> ■ Allows the user to control the HTF target application temperature. ■ Shows the actual temperature of the HTF. |
| f | Cab light ON-OFF switch | Switches electric power ON and OFF to the cab light. |
| g | Hose rewind ON-OFF switch | Switches electric power ON and OFF to the hose rewind motor. |
| h | Burner ON-OFF switch | Switches electric power ON and OFF to the burner. |
| i | Pump 2 ON-OFF switch | Switches electric power ON and OFF to Pump 2. |
| j | Pump 1 ON-OFF switch | Switches electric power ON and OFF to Pump 1. |
| k | HTF fill switch | This momentary switch bypasses the low-level shut-down device and provides power to the pumps. It is used when filling the HTF reservoir after a low level fault. |
| l | Low level fault indicator | Illuminates to indicate a low HTF level condition. |
| m | Burner fault indicator | Illuminates to indicate a burner fault condition. |
| n | Line 1 GFCI | Provides protection for the operator. |
| o | Thermal switch (snap switch) | Disconnects power to the burner circuit in the event of an over-temperature condition. This switch opens at 70°C. This switch must be manually reset. |
| p | HTF low-level reset switch (module is located inside the auxiliary control panel) | Pressing this switch resets the low-level shut-down device. |

4.5 Pumps, Gauges, and Valves

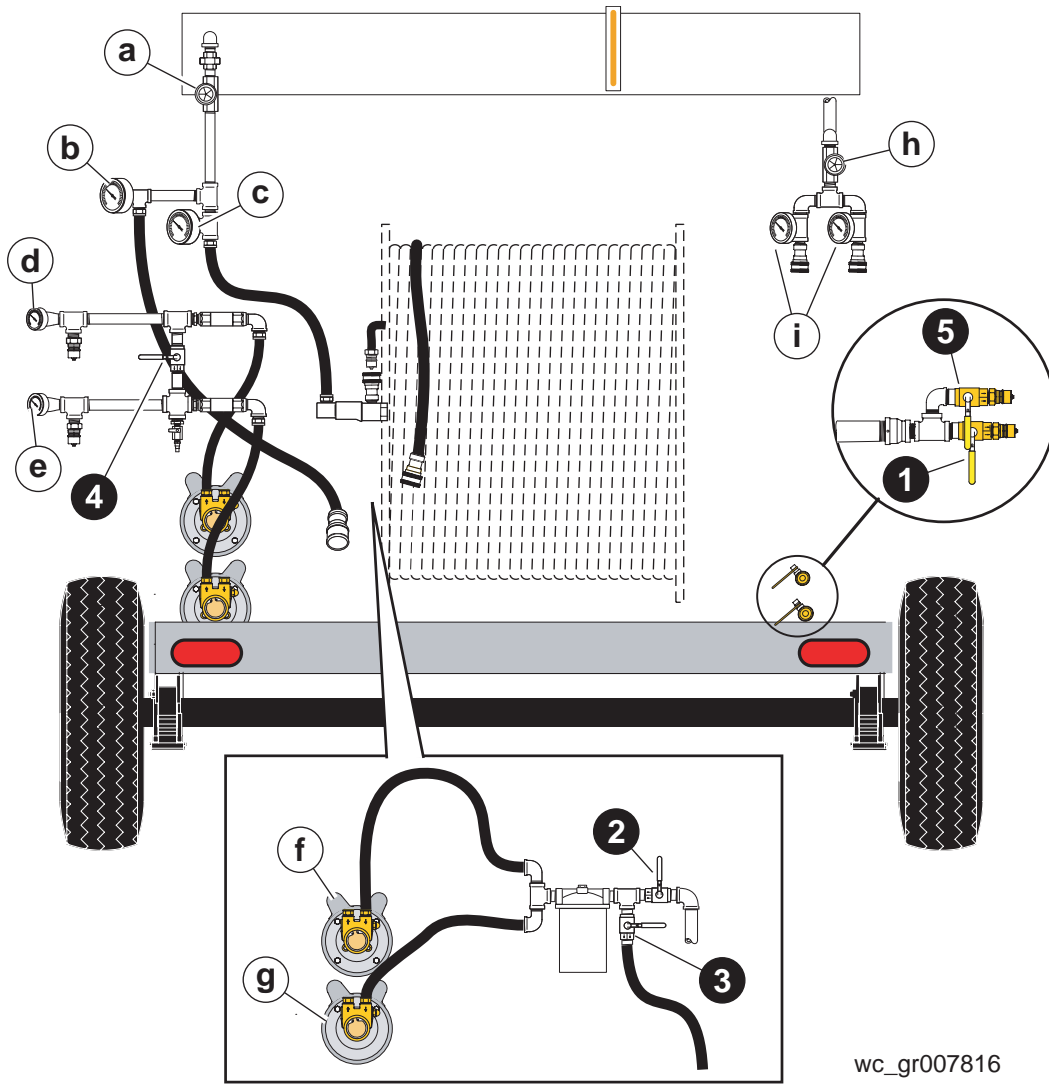

Pumps and Gauges

| Ref. | Description | Ref. | Description |
|------|--------------------------------|------|--|
| a | Return flow indicator | f | Pump 1 |
| b | Loop 1 return flow temperature | g | Pump 2 |
| c | Loop 2 return flow temperature | h | Auxiliary return flow indicator |
| d | Loop 1 supply flow pressure | i | Auxiliary return flow temperature (quantity 1 on E 3000ES) |
| e | Loop 2 supply flow pressure | — | — |

Valves

| Valve # | Description | Valve # | Description |
|---------|--------------------|---------|---|
| 1 | Pump Pack supply | 4 | Cross connect valve |
| 2 | Pump suction valve | 5 | Pump Pack supply (not included on E 3000ES) |
| 3 | HTF fill valve | — | — |

4.6 Preparing the Machine for First Use

Preparing for first use

To prepare your machine for first use:

1. Make sure all loose packaging materials have been removed from the machine.
2. Check the machine and its components for damage. If there is visible damage, do not operate the machine! Contact your Wacker Neuson dealer immediately for assistance.
3. Take inventory of all items included with the machine and verify that all loose components and fasteners are accounted for.
4. Attach component parts not already attached.
5. Add fluids as needed and applicable, including fuel, engine oil, and battery acid.
6. Move the machine to its operating location.

4.7 General Sequence of Operation

Follow the sequence of operation below. Refer to the specific topic for details.

| Task | When/Where | See Topic |
|--|--|------------------|
| 1. Check HTF level. | Before leaving for the job site. Or, when at the job site before daily operation. | 4.10 |
| 2. Check fuel level. | | 4.10 |
| 3. Position the machine. | At the job site. | 4.9 |
| 4. Connect power. | | 4.11 |
| 5. Perform "Pre-Starting" checks. | | 4.10 |
| 6. Start the generator (if equipped) | | 4.12 |
| 7. Preheat the HTF (if necessary) and initiate HTF flow. | | 4.13. 4.14 |
| 8. Set the operating temperature. | | 4.15 |
| 9. Unwind and position the hoses. | | 4.16 |
| 10. Monitor the operating parameters. | | 4.17 |
| 11. Rewind the hoses. | | 4.19 |
| 12. Stop the machine. | | 4.18 |
| 13. Shut down and pack up the machine. | | 4.20 |

4.8 Recommended Fuel

Low ambient temperatures cause diesel fuels to gel. Gelled fuels will cause burner ignition failure and/or burner fuel pump damage. Always use the proper fuel for the conditions.

| Fuel Blend Guide | | |
|--|--|---|
| Lowest expected ambient temperature °F (°C) | Generator powered | Shore powered |
| Below 5 (-15) | 50-50 blend of #2 diesel and #1 diesel, plus additives OR 50-50 blend #2 diesel and K1 kerosene, plus additives | 100% #1 diesel plus additives OR 100% K1 kerosene, plus additives |
| 5 to 25 (-15 to -4) | 70-30 blend of #2 diesel and #1 diesel, plus additives OR 70-30 blend of #2 diesel and K1 kerosene, plus additives | |
| Above 25 (-4) | Winter-blend diesel | |

4.9 Positioning the Machine

**DANGER**

Asphyxiation hazard.

Exhaust gas from the burner contains carbon monoxide, a deadly poison you cannot see or smell. Exposure to carbon monoxide can kill you in minutes.

- ▶ Position the machine so that burner exhaust will not enter any nearby structures.

**WARNING**

Fire hazard. Do not move the machine while it is running.

- ▶ Shut down the machine before moving or repositioning it.

**WARNING**

Fire hazard. Machines positioned on a hill or an incline may slide, break away or roll over.

- ▶ Do not position the machine on a hill or an incline.

CO Alarms

Because this machine produces carbon monoxide (CO), Wacker Neuson recommends that CO alarms be installed in all structures in close proximity to the machine. CO alarms provide an extra measure of protection against this poison that you cannot see or smell.

Install battery-operated CO alarms or plug-in CO alarms with battery backup, according to the manufacturer's instructions. CO alarms should be certified to the requirements of the latest safety standards (UL 2034, IAS 6-96, or CSA 6.19.01). Test the CO alarm batteries monthly.

Requirements

Position the machine:

- So that burner exhaust will not enter nearby structures.
- So that the machine does not block traffic.
- So that the machine is not close to any combustible material.
- So that all of the machine's access doors/panels may be accessed.
- So that HTF hoses do not pose tripping hazards, and so the HTF hoses cannot be damaged by machines or other equipment on the job site.

Procedure

This procedure continues on the next page.

Continued from the previous page.

Perform the following procedure to position the machine.

1. Place the machine near the application area **(a)** on solid, stable, and level ground.

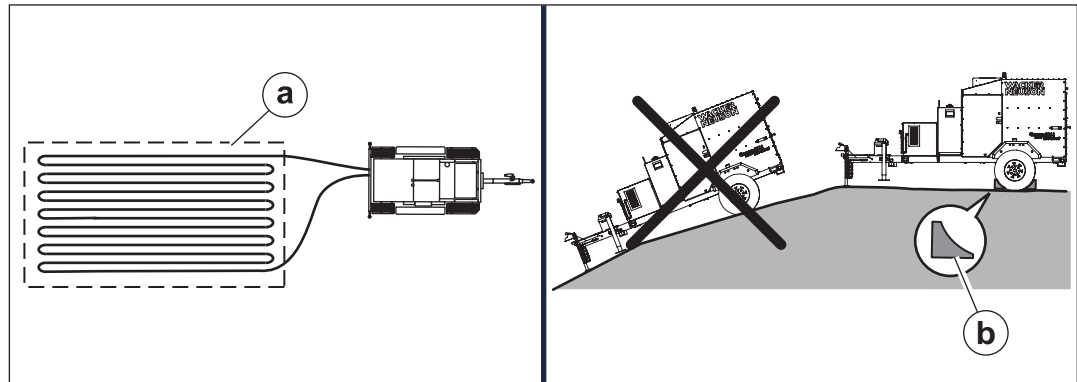

wc_gr008055

2. For machines with trailers, install chocks **(b)** under the wheels.

Result



The machine is now properly positioned.

4.10 Pre-Starting Checks

Prerequisites ■ Machine properly positioned

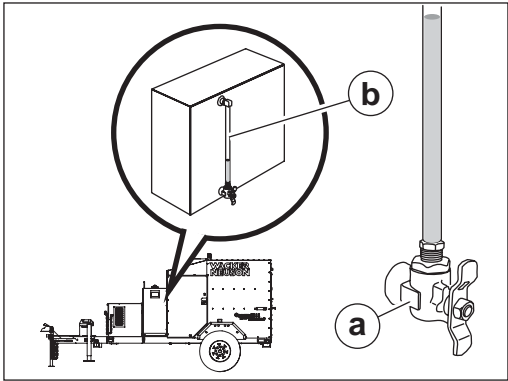
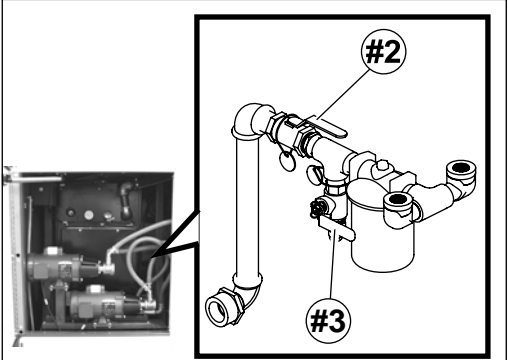
Checks Before starting the machine, check the following items:

| Fuel System | |
|--|--|
| <p>Fuel sight gauge valve (a)</p> <p>▶ Check that the fuel sight gauge valve is open.</p> |  <p>wc_gr008057</p> |
| <p>Fuel sight gauge (b)</p> <p>▶ Check that there is fuel in the tank.</p> | |
| | |
| Heat Transfer Fluid (HTF) System | |
| <p>Suction valve (#2)</p> <p>▶ Check that suction valve (#2) is opened.</p> |  <p>wc_gr007784</p> |
| <p>HTF fill valve (#3)</p> <p>▶ Check that HTF fill valve (#3) is closed and locked with the locking pin.</p> | |
| <p>NOTICE: The HTF fill valve must remain closed and locked during normal operation. An open HTF fill valve will cause HTF leakage.</p> | |

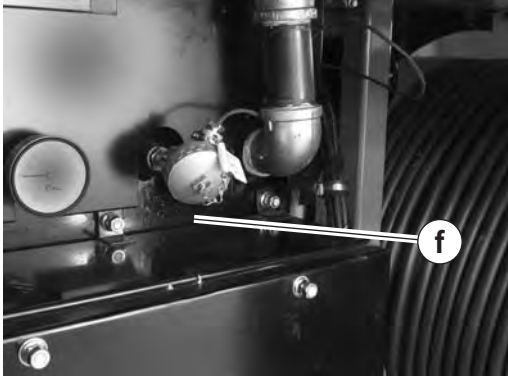
| | |
|---|---|
| <p>HTF sight gauge (c)</p> <ul style="list-style-type: none"> ▶ Check that the HTF level is within the operating range. <p>NOTICE: Starting the machine with low HTF will damage the pumps.</p> |  <p>Serial No. 11122000</p> <p>HTF LEVEL</p> <p>MAX</p> <p>MIN</p> <p>wc_gr008056</p> |
| <p>HTF Hose connections (e)</p> <ul style="list-style-type: none"> ▶ Check that all HTF hose quick-connects are secure. |  <p>wc_gr008059</p> |
| <p>Hydronic heater (f)</p> <ul style="list-style-type: none"> ▶ Inspect for signs of exhaust leaks. See topic <i>Inspecting/Replacing the Rope Gasket</i>. |  <p>wc_gr008059</p> |

Result

The machine is ready to have power applied.

4.11 Connecting Power to the Machine

- Prerequisites**
- Power source
 - Machine properly positioned



WARNING

Fire hazard and electric shock hazard. The use of under-sized extension cords can lead to fire and electric shock. Fire and electric shock can cause severe injury.

- ▶ Do not use under-sized extension cords.

Extension cords

Restrictions for extension cords:

- Use only 3-wire type extension cords with heavy-duty plugs.
- The maximum length of extension cord usage per circuit is 30 m (100 ft).
- Use 12-gauge extension cords for lengths up to 15 m (50 ft).
- Use 10-gauge extension cords for lengths up to 30 m (100 ft).

Procedure

Follow the procedure below to connect power to the machine.

1. Move both circuit breaker switches (**a** and **b**) to the OFF position.

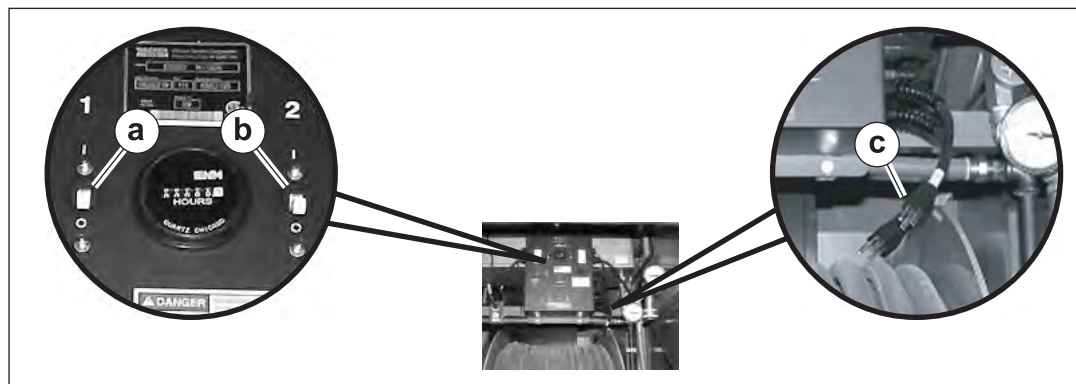

wc_gr006372

2. Connect the main power cords (**c**) to a properly-rated power source or to the generator if included.

Result

Power has now been connected. The machine is ready for pre-starting checks.

4.12 Starting and Stopping the Generator

Background Only general starting and stopping procedures for the generator are included in this manual. See the generator manufacturer's operation manual for detailed procedures.

Starting Perform the procedure below to start the generator.

1. Move the circuit breaker switches on the genset to the OFF position.
2. Prime the fuel system if needed. The fuel system will need to be primed if:
 - Fuel system has run dry
 - Fuel system has been drained
 - The fuel filter has been changed
 - The genset has not been run for several weeks

► To prime the fuel system: Press and hold the control switch in the "Stop / Prime" position. The fuel pump will start two seconds after the control switch is initially placed in the "Stop / Prime" position. Continue holding the control switch for at least one minute.

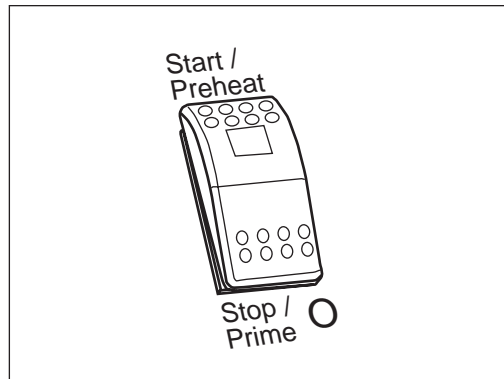

wc_gr007811

3. Press and hold the control switch in the "Start / Preheat" position. The genset will first preheat (for up to 15 seconds depending on how cold it is). Then, the starter will engage and the engine will start.

NOTICE: Do not crank the engine for more than 30 seconds at a time. Wait at least two minutes before cranking the engine again.

Stopping Perform the procedure below to stop the genset.

1. Move the generator circuit breakers to the OFF position.
2. Allow the genset to run two minutes to cool down.
3. Press the control switch to the "Stop / Prime" position.

4.13 Preheating the HTF

NOTICE: Starting the machine with frozen or partially frozen Heat Transfer Fluid (HTF) will permanently damage the pumps. Preheat the HTF when ambient air temperature is below -26°C (-15°F).

- Prerequisites**
- HTF reservoir full
 - Machine powered up

Procedure Follow the procedure below to preheat the HTF.

1. Use the up and down arrows **(a)** on the temperature controller to set the HTF temperature to 100°F (38°C). This is the set point temperature.



wc_gr008061

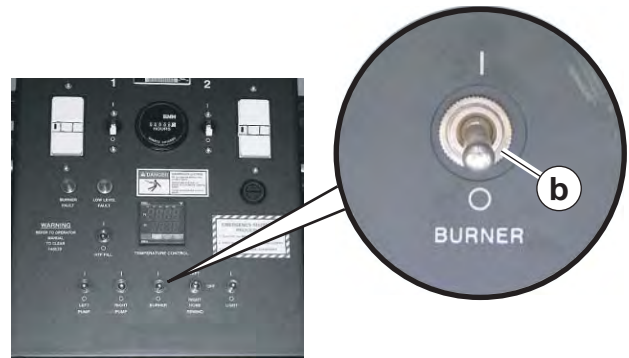

ghi_gr006377

2. Move the burner ON/OFF switch **(b)** to the ON position. The following sequence occurs:
 - a. The burner motor starts after a 5-second delay.
 - b. The burner fires after a 15-second delay.
 - c. The burner will operate, with little or no visible exhaust smoke, until the HTF reaches the set point temperature, at which time, the burner will stop firing.
 - d. The burner will re-fire if the set point temperature is increased or the temperature of the HTF falls below 100°F (38°C).

Note: The temperature of the HTF is displayed **(c)** in red.



wc_gr008062

Result When the temperature controller displays “100.0” **(c)** the HTF is preheated.

4.14 Initiating HTF Flow

- Prerequisites**
- Heat Transfer Fluid (HTF) preheated. See topic *Preheating the HTF*
 - Hand protection



CAUTION

Burn hazard. The hoses and components of the plumbing system may be very hot. Hot hoses and hot plumbing components may cause severe burns.

- ▶ Wear hand protection when handling hot hoses or hot plumbing components.

Note: *If you are using accessories, see Chapter “Accessories”.*

Procedure

Follow the procedure below to initiate HTF flow.

1. Verify that the operation valve **(2)** is in the OPEN position.

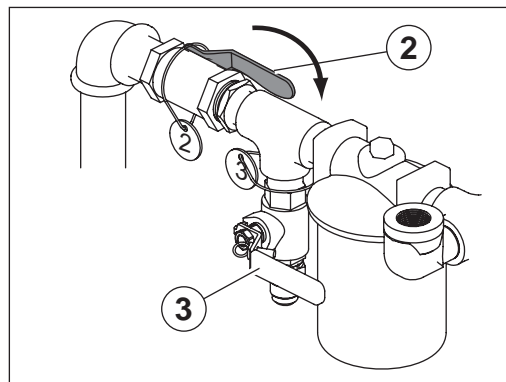

wc_gr007786

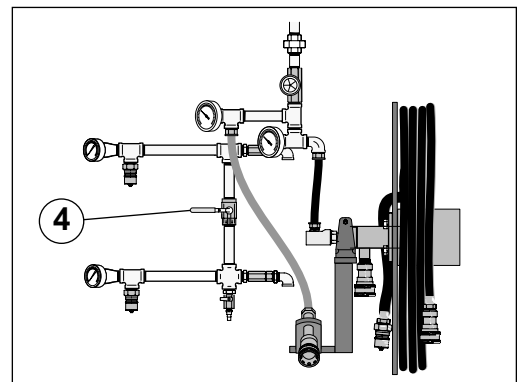

wc_gr007815

2. Verify that the fill valve **(3)** is in the CLOSED position. Lock it in the closed position with the locking pin.
3. Close the cross connect valve **(4)**.

This procedure continues on the next page.

Continued from the previous page.

NOTICE: Operate only pump 1 when both hose loops are connected together. Turning on pump 1 and pump 2—with the hoses connected together—may cause pump damage.

4. Connect hose loop 1 (female QC) **(f)** to the supply port (male QC).
5. Connect hose loop 2 (male QC) **(g)** to the return port (female QC).

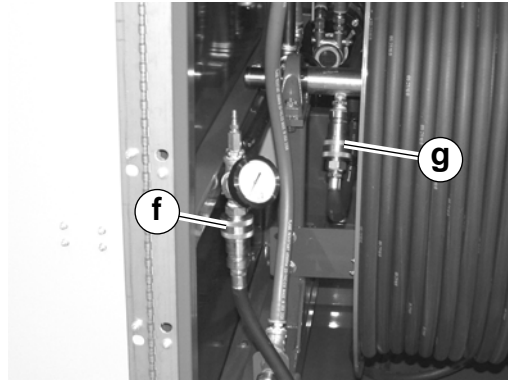

wc_gr007797

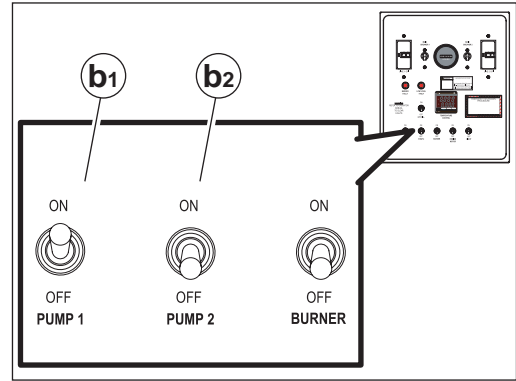

wc_gr008063

6. Move pump 1 ON-OFF switch **(b₁)** to the ON position. The HTF will flow through both loops.
7. Verify rising pressure by checking the pump 1 pressure gauge **(h)** and the flow indicator **(i)**.



wc_gr007798



wc_gr007799

NOTICE: If the HTF reaches 170 psi (11.7 bar) after only a second or two of operation, there is a problem. Shut down the machine and rectify the problem before continuing.

- Once flow is established, pressure should be: 125–140 psi (8.6–9.6 bar).
- When the HTF is warm, operating pressure should be: 90–110 psi (6.2–7.6 bar).

8. Check the HTF flow indicator **(f)**. The flow indicator should be spinning. If it is not, there is a problem. Shut down the machine and rectify the problem before continuing.

Result

The HTF is now flowing. The hoses may now be unwound and positioned.

4.15 Setting the Operating Temperature

Operating temperature

Once the HTF is preheated, set the temperature controller to the operating temperature. Use the chart below as a guide.

| Operation type | Recommended Temperature Setting |
|-----------------|--|
| Ground thawing | 80°C (180°F) |
| Concrete curing | 7°C (20°F) above the desired temperature of the concrete |
| Air heating | 80°C (180°F) |

4.16 Positioning the Hoses and Operating the Machine

- Prerequisites**
- “Pre-Starting” checks completed. See topic *Pre-Starting Checks*.
 - HTF preheated. See topic *Preheating the HTF* and topic *Initiating HTF Flow*.



CAUTION

Hoses may be very hot. You may be burned if proper precautions are not taken.
 ► Wear hand protection when handling hoses and hot components.

NOTICE: This machine uses two hose loops during operation (curing, thawing, heating). The hose loops must be disconnected from each other before operating the machine. Do not turn on both pumps with the hoses connected to each other.

Unwind and position the hoses

Perform the procedure below to unwind and position the hoses.

Note: *Unwind hose loop 1 with pump 1 turned on.*

1. Close the cross connect valve (4).

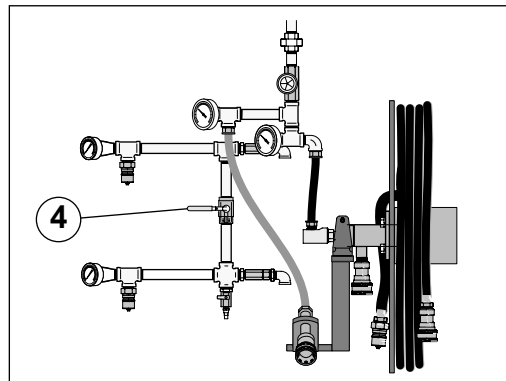

wc_gr007815

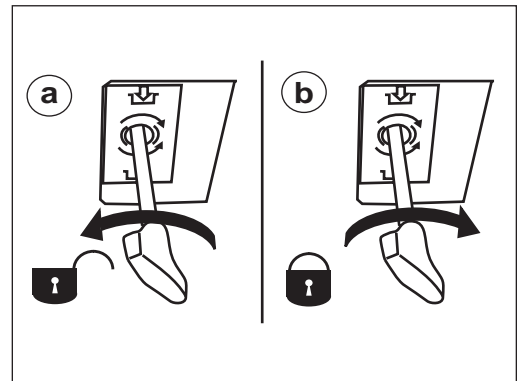

wc_gr007801

2. Turn the hose reel brake T-handle counterclockwise (a) to release the brake.
3. Unwind hose loop 1 (position hose loop 1 in the application area while unwinding) until the quick connect coupling that connects loop 1 with loop 2 is exposed. Then, turn off pump 1.
4. Allow the pressure to drop to 0 psig.
5. Disconnect loop 1 from loop 2.



wc_gr007803

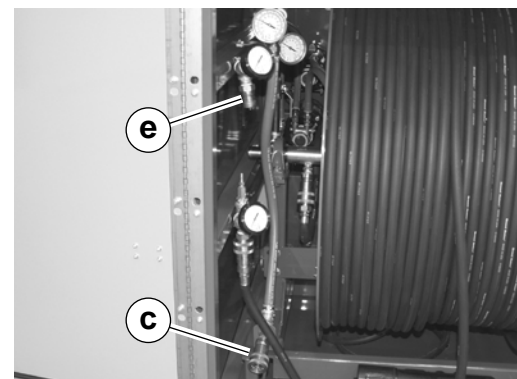

wc_gr007800

6. Connect loop 1 (male quick connect) to the return port (c).

7. Connect loop 2 (female quick connect) to the supply port **(e)**.
8. Unwind loop 2 from the hose reel and position it within the application area. Use caution when nearing the end of the hose loop so that the hose loop is not damaged due to over spinning of the hose reel.
9. Turn the hose reel brake T-handle clockwise **(b)** to engage the brake.
10. Move pump 1 and pump 2 ON-OFF switches to the ON position.
11. Set the temperature controller to the appropriate temperature for the application. See topic *Setting the Operating Temperature*.

Hose spacing

Refer to the table below for the appropriate hose spacing specifications.

To increase heat penetration, cover the hoses with a plastic vapor barrier and two layers of insulated blankets. For concrete curing, cover the concrete with plastic, place the hoses on top of the plastic, then cover the hoses with two layers of insulated blankets.

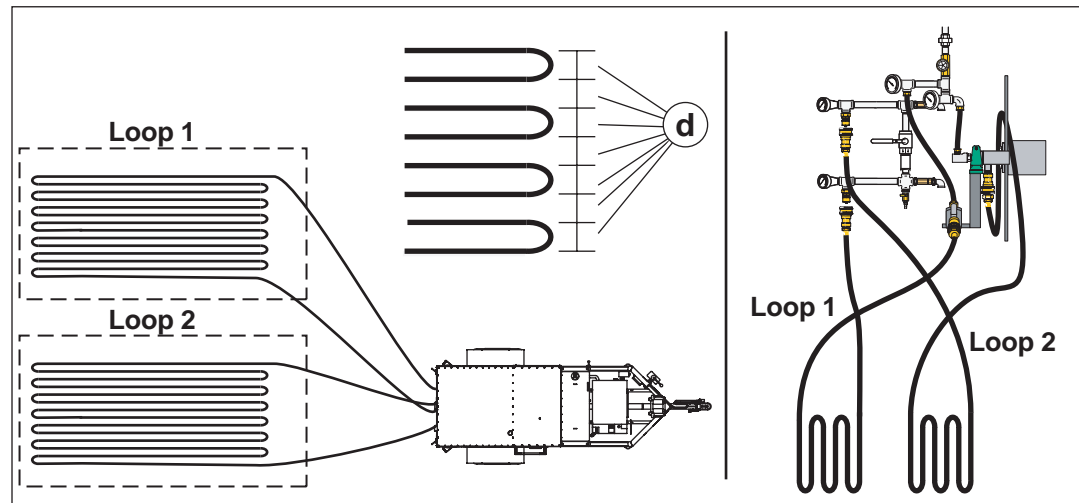

wc_gr007802

| Distance (d) | Application | Description |
|-------------------------------|-------------------|--|
| 91.5 cm (36 in.) | Frost prevention | Prevents frost in the application area. |
| 61 cm (24 in.) | Concrete curing | Allows concrete to cure. |
| 46 – 61 cm (18 – 24 in.) | Excavation thaw | Partially thaws the ground for excavation. |
| 30.5 – 46 cm (12 – 18 in.) | Contractor's thaw | Completely thaws the ground for site work. |
| 15 cm (6 in.) | Accelerated thaw | Up to 50% faster than contractor's thaw. |

Result

The machine is now operating. Monitor the operating parameters while the machine is operating. See topic *Monitoring the Operating Parameters*.

4.17 Monitoring the Operating Parameters

Background Monitor the machine while it is operating to ensure safe and efficient operation.

Parameters Monitor the following parameters every 8–24 hours.

| Parameter | Notes |
|------------------------|--|
| Fuel level | Add fuel as needed. |
| HTF level | Add HTF as needed. |
| HTF operating pressure | Operating pressure: 90–110 psi. If operating pressure is higher than 110 psi, check for kinked hoses. If operating pressure is less than 90 psi, check HTF level. |
| HTF return temperature | The HTF return temperature tells you how much heat is being transferred. It can also tell you when a thawing process is complete, as very little heat will be transferred at that point. Consult Wacker Neuson Product Support for detailed information. |
| Strobe light | Flashing strobe signifies that all systems are OK. |

4.18 Stopping the Machine Temporarily

Precautions **NOTICE:** This procedure is to be used for stopping the machine temporarily for routine maintenance such as refueling or repositioning hoses. Do not use this procedure for any other purpose.

Stopping the machine

Follow the procedure below to stop the machine temporarily.

1. Move the burner ON-OFF switch **(a)** to the OFF position.

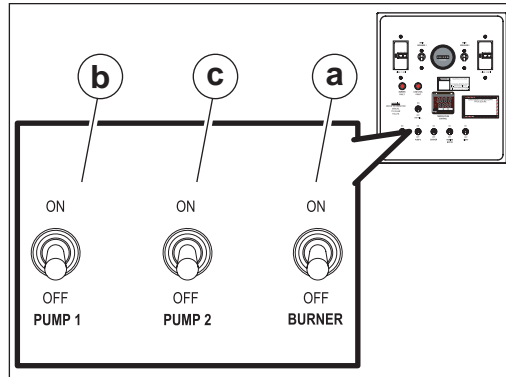

wc_gr008084

2. Allow the burner to complete the burner-motor-off delay period.
3. Move the pump ON-OFF switches **(b and c)** to the OFF position.
4. Turn off all accessories if applicable.

Your machine is now stopped.

Perform the necessary task(s) (refueling, repositioning hoses, etc.).

Restarting the machine

Follow the procedure below to restart the machine.

1. Move the burner ON-OFF switch **(a)** to the ON position.
2. Wait until the burner fires.
3. Move the pump ON-OFF switches **(b and c)** to the ON position.
4. Start accessories if applicable.

Result

Your machine has resumed operating.

4.19 Rewinding the Hoses

- Requirements**
- All accessories off, if applicable
 - Machine turned on



CAUTION

Hot surface hazard. Hoses may be very hot.
 ► Wear hand protection while handling hoses.

Procedure

Perform the procedure below to rewind the hose.

Note: Having warm HTF circulate through the hose will aid in rewinding of the hose. Rewind the hoses with the burner firing.

1. Turn the T-handle **(a)** counterclockwise to unlock the hose reel.

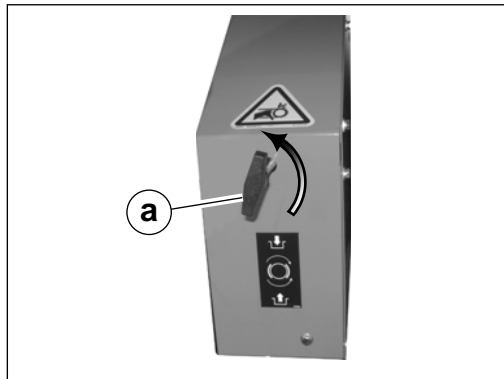

wc_gr007885

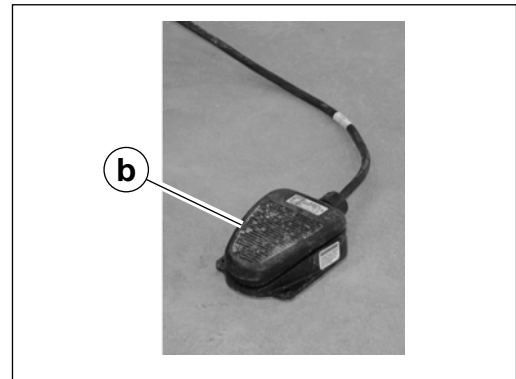

wc_gr007886

2. Remove the foot pedal **(b)** and place it on a firm, flat, and dry surface.
3. Move Pump 2 ON-OFF switch **(c)** to the ON position.

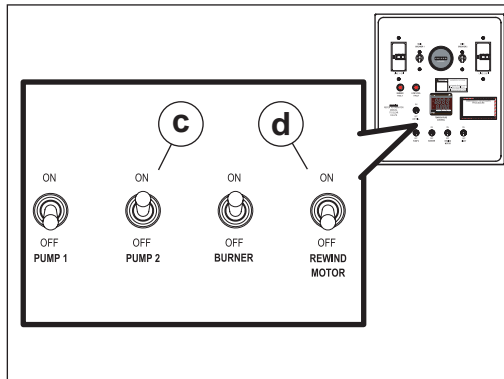

wc_gr008064

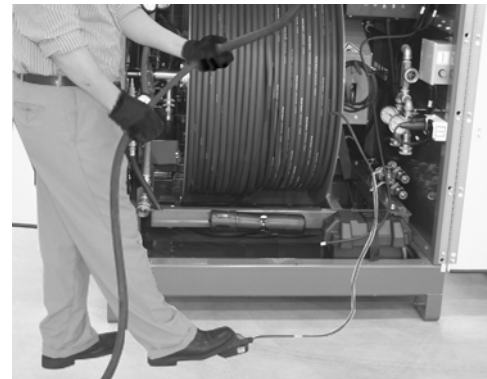

wc_gr007892

4. Move the hose rewind ON-OFF switch **(d)** to the ON position.
Note: The rewind motor will start but will not rotate the hose reel until the clutch is engaged.
5. Press down on the foot pedal to engage the clutch. The hose reel will rotate.
6. Guide hose loop 2 evenly onto the hose reel as it rotates.

This procedure continues on the next page.

Continued from the previous page.

NOTICE: Disengage the clutch (release the foot pedal) before reaching the hose end. Failure to do so may damage the machine.

7. Release the foot pedal to disengage the clutch approximately six feet from the end of the hose.
8. Manually wind the remainder of the hose onto the reel.
9. Move Pump 2 ON-OFF switch to the OFF position.
10. Connect hose loop 1 to hose loop 2.



wc_gr007803

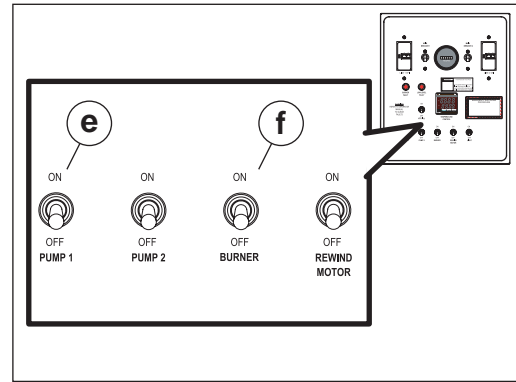

wc_gr008065

11. Move Pump 1 ON-OFF switch **(e)** to the ON position.
12. Rewind hose loop 1 as you did hose loop 2.
13. Move Pump 1 ON-OFF switch to the OFF position.
14. Engage the hose reel brake by turning the T-handle **(a)** clockwise.
15. Return the foot pedal to its storage location.
16. Move the burner ON-OFF switch **(f)** to the OFF position.

Result

The hoses are now wound onto the hose reel and your machine is ready to be placed into storage. See topic *Storing the Machine*.

4.20 Shutting Down and Packing Up the Machine

Shutting down

Perform the procedure below to shut down the machine.

1. Move the burner ON-OFF switch **(a)** to the OFF position.

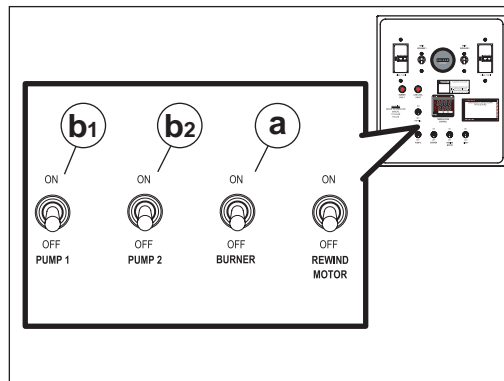

wc_gr008066

2. Move the pump ON-OFF switches **(b₁** and **b₂)** to the OFF position.
3. Turn off all accessories if applicable.
4. Rewind the hoses. See topic *Rewinding the Hoses*.
5. Move the circuit breaker ON-OFF switches **(e)** to the OFF position.

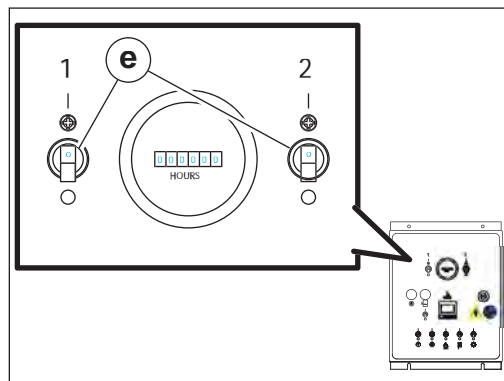

wc_gr008067

The machine is now shut down and ready to be packed up.

Packing up the machine

Perform the following procedure to pack up the machine.

1. Disconnect and store all accessories.
2. Disconnect power from the machine.
3. Close and lock all doors.

The machine is now ready to be stored.

4.21 Resetting a Low HTF Level Fault

- Requirements**
- Genuine Wacker Neuson Heat Transfer Fluid
 - Power connected to the machine

NOTICE: Use only factory-recommended Heat Transfer Fluid (HTF). Failure to do so may damage the machine.

Background

The HTF reservoir includes a sensor that will trigger the low-level shut-down device to stop the machine's function if the HTF falls below the minimum operational capacity. During a low HTF level condition the following occur:

- The control panel low level fault light illuminates
- Power is disconnected from the burner
- Power is disconnected from the pumps

Turn off the burner and the pumps

1. Move the burner ON-OFF switch (**a**) to the OFF position.

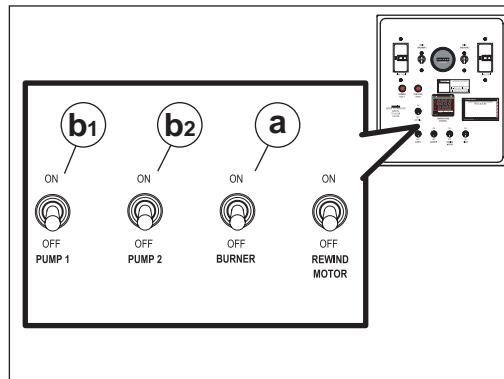

wc_gr008066

2. Move the pump ON-OFF switches (**b₁** and **b₂**) to the OFF position.

Fill the HTF reservoir

1. Move the operation valve (**2**) to the CLOSED position.

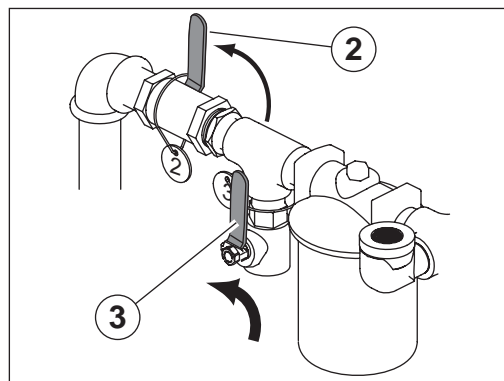

wc_gr007807

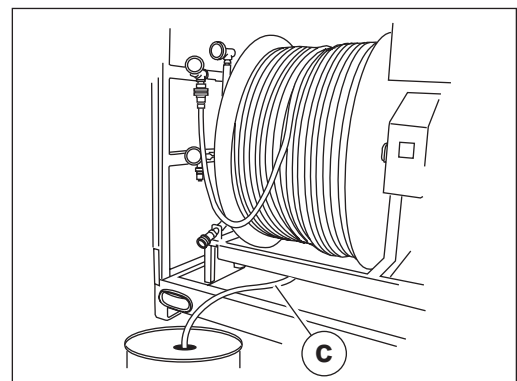

wc_gr008071

2. Remove the pin and move the fill valve (**3**) to the OPEN position.
3. Remove the fill hose (**c**) from its storage location under the hose reel. Remove the cap from the hose if a cap is provided. Clean the fill hose if necessary.

This procedure continues on the next page.

Continued from the previous page.

4. Place the open end of the fill hose into a container of HTF.
5. Move and hold the bypass switch (**x**) in the ON position. HTF will begin to flow. When the HTF level is between the minimum and maximum marks on the sightglass:
 - a. Pull the fill hose from the HTF supply.
 - b. Release the bypass switch.

NOTICE: Do not overfill the HTF reservoir.

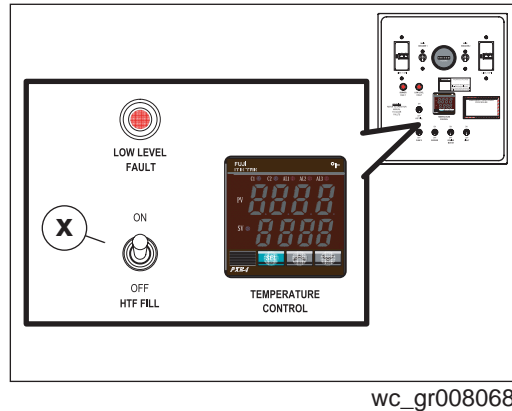

Prepare machine for operation

After filling the HTF reservoir, perform the procedure below to prepare the machine for operation.

1. Press and release the “RESET” button (**d**) on the low-level shut-down device.

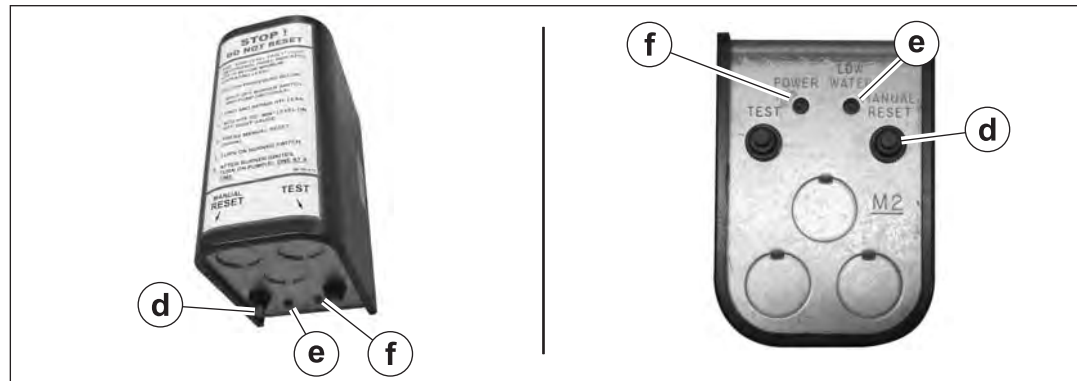

The following will occur:

- The “POWER” (green) (**f**) and “LOW WATER” (red) (**e**) lights will blink for fifteen seconds while the low-level shut-down device performs a self-diagnostic test.
- After 15 seconds, the “LOW WATER” light will go out—the “POWER” light will stay on.
- The low HTF level indicator will go out.
- Power will be returned to the pump circuit.
- Power will be returned to the burner circuit.

This procedure continues on the next page.

Continued from the previous page.

2. Move the fill valve **(3)** to the CLOSED position and insert the pin.

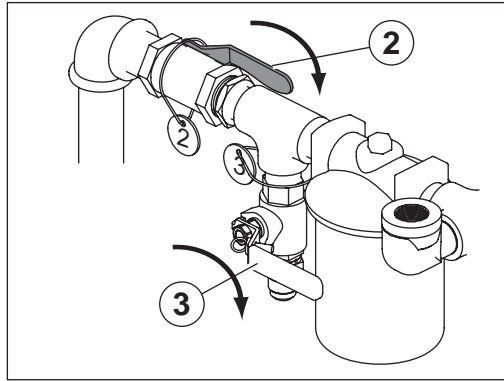

wc_gr007810

3. Move the operation valve **(2)** to the OPEN position.
4. Clean the fill hose, and cap the fill hose if a cap is provided.
5. Return the fill hose to its storage location under the hose reel.

Result

The machine is now ready for operation.

4.22 Quick-Connect Coupling Usage and Care



CAUTION

Burn hazard. The hoses and components of the plumbing system may be very hot. Hot hoses and hot plumbing components may cause severe burns.
 ► Wear gloves when handling hot hoses and plumbing components.

Precautions

- Do not join or separate quick-connect couplings when the pressure gauge indicates the lines are pressurized.
- Do not join or separate quick-connect couplings when the HTF temperature is above 48°C (120°F).
- Do not use damaged quick-connect couplings.
- Do not use dirty or contaminated quick-connect couplings.
- Do not lubricate quick-connect couplings.

Usage Instructions

Follow the instructions below when using the quick-connect couplings.

1. Clean both the male **(a)** and female **(b)** couplings before and after each use.
2. Push and hold the locking collar **(c)** on the female coupling **(b)** down.
3. Insert the male coupling **(a)**.
4. Release the locking collar to lock.

Cleaning Instructions

Follow the instructions below when cleaning the quick-connect couplings.

1. Rinse each coupling with clean water before and after each use.
Note: *Be sure that each coupling is free of dirt and debris.*
2. Inspect seals and gaskets before and after each use.
3. Install caps or protective covers after each use.

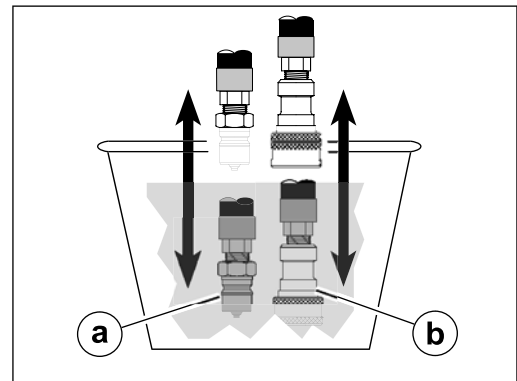
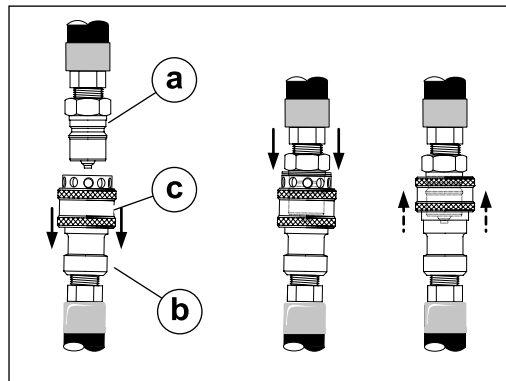

ghi_gr005291

4.23 Resetting the Snap Switch

Background The thermal overload switch (snap switch) opens when the temperature of the Heat Transfer Fluid (HTF) reaches 88°C (190°F). When the snap switch opens, electric power is disconnected from the burner. The snap switch must be manually reset to reconnect power to the burner.

NOTICE: If the snap switch opens, locate and resolve the reason why it opened before using the machine.



WARNING

Burn hazard. Hot piping and hot HTF can cause burns.

- ▶ Allow the machine to cool before attempting to reset the snap switch.
-

Procedure Perform the procedure below to reset the snap switch.

1. Locate the snap switch **(a)** on top of the hydronic heater.

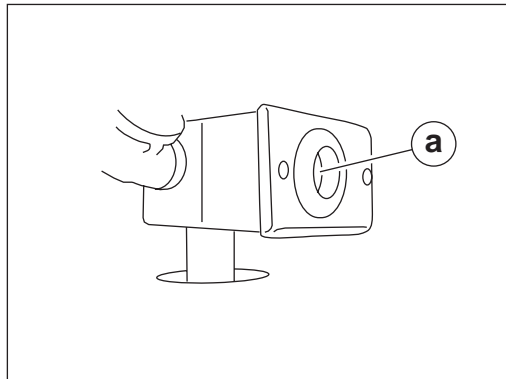

wc_gr007878

2. Press the reset button.
-

Result The snap switch has now been reset.

4.24 Burner Controller Periods and Modes

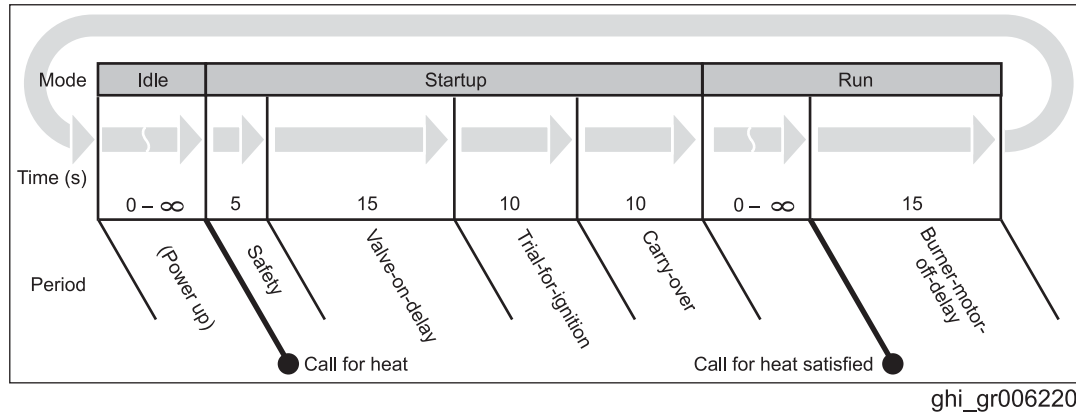

Periods

The burner controller has several periods it sequences through during normal operation. These periods are described below.

| Period | Action or Function |
|--------------------|---|
| Power up | As soon as power is supplied to the burner controller, it conducts an internal safety check. If all internal conditions are OK, the burner controller enters the idle mode and will remain there until there is a call for heat, or power is disconnected. |
| Safety (5 seconds) | <p>When the setpoint of the temperature controller is set at a temperature higher than that of the heat transfer fluid, the output contacts of the temperature controller close, completing a circuit between terminal “T” and “3T” of the burner controller. This is the call for heat.</p> <p>The burner controller initiates the safety period.</p> <p>If flame or light is detected, the burner controller remains in the idle mode and no other functions take place.</p> <p>If flame or light is not detected after 5 seconds:</p> <ul style="list-style-type: none"> ■ Power is sent to the burner motor/fuel pump. Fuel is pumped from the supply tank and returned to the supply tank through the return/bypass port of the fuel pump. This process purges air from the fuel lines. ■ Power is sent to the electrodes and any residual fuel is burned off. ■ Fresh air fills the combustion chamber. ■ The valve-on-delay period starts. |
| Valve-on-delay | <p>The valve-on-delay period lasts 15 seconds. It is enabled (turned on or off) with DIP switch 3. When enabled:</p> <ul style="list-style-type: none"> ■ Power is sent to the burner motor/fuel pump. ■ Power is sent to the electrodes. ■ The fuel shut-off valve is energized (opens) and fuel flows to the nozzle after the valve-on-delay times out. |

| Period | Action or Function |
|------------------------|--|
| Trial-for-ignition | <p>The trial-for-ignition period immediately follows the valve-on-delay period. During this period:</p> <ul style="list-style-type: none"> ■ The fuel shut-off valve is opened (energized). ■ Pressurized fuel atomizes at the burner nozzle. ■ The atomized fuel is vaporized and ignited by the electrodes. ■ The burner fires and the flame is monitored by the cad cell. <p>If flame is not detected:</p> <ul style="list-style-type: none"> ■ The burner controller enters lockout mode. ■ Power is disconnected from the fuel shut-off valve, electrodes, and the burner motor. ■ The indicator light flashes. |
| Carry-over | <p>The ignition carry-over period starts as soon as the flame is established. During this cycle:</p> <ul style="list-style-type: none"> ■ The fuel shut-off valve is open (energized). ■ Pressurized fuel atomizes at the burner nozzle. ■ The atomized fuel is ignited by the electrodes. ■ The electrodes stay powered for up to 30 seconds after flame is sensed. <p>Once the carry-over period has expired:</p> <ul style="list-style-type: none"> ■ The ignition transformer is shut off. ■ The burner controller enters the run mode. <p>If the flame is lost:</p> <ul style="list-style-type: none"> ■ If the lockout time has not expired, the burner controller returns to trial-for-ignition period. ■ If the lockout time has expired, the burner controller enters the recycle mode. |
| Burner-motor-off delay | <p>The burner-motor-off-delay period starts immediately after the setpoint is reached, i.e., the call for heat has been satisfied. The time of this period is set by the DIP switches (DIP switches 1 and 2 in the down position; 3 in the up position). During this period:</p> <ul style="list-style-type: none"> ■ The fuel shut-off valve is closed (de-energized). ■ The burner motor runs until the burner-motor-off delay expires, then the burner motor turns off. ■ The burner controller returns to the idle mode. |

Non-fault modes

The burner non-fault modes are described below.

| Mode | Functional description |
|------|--|
| Idle | <p>The burner controller will enter the idle mode if:</p> <ul style="list-style-type: none"> ■ At power-up, the internal conditions are correct and the cad cell senses no light. ■ The cad cell senses light during the safety period. ■ The call for heat has been satisfied. <p>During this mode:</p> <ul style="list-style-type: none"> ■ The burner controller powers no outputs. |

| Mode | Functional description |
|---------|--|
| Startup | <p>The burner controller will enter the startup mode as soon as there is a call for heat. This mode consists of the following periods:</p> <ul style="list-style-type: none"> ■ Safety ■ Valve-on-delay ■ Trial-for-ignition ■ Carry-over |
| Run | <p>The run mode starts and continues once the ignition carry-over period has elapsed. During this mode:</p> <ul style="list-style-type: none"> ■ The fuel shut-off valve is open (energized). ■ Pressurized fuel atomizes at the burner nozzle. ■ The flame is monitored by the cad cell. <p>Once the setpoint is reached (call for heat satisfied):</p> <ul style="list-style-type: none"> ■ The output contacts of the temperature control open, interrupting the circuit between terminal "T" and "3T". ■ The fuel shut-off valve is closed (de-energized). ■ The burner motor runs for the selected burner-motor-off delay time (period), then turns off. ■ The burner controller returns to the idle mode. <p>If the flame is lost during the run mode:</p> <ul style="list-style-type: none"> ■ The burner controller enters the recycle mode. |
| Recycle | <p>The burner will enter the recycle mode when the burner stops firing due to loss of flame. During the recycle mode:</p> <ul style="list-style-type: none"> ■ The diagnostic light on the burner controller will flash in two-second intervals. ■ The burner will attempt to automatically restart. <ul style="list-style-type: none"> ■ Flame must be detected during each restart attempt. If no flame is detected, the burner controller goes into burner fault lockout mode. ■ The burner controller will wait 60 seconds between restart attempts. ■ After three restart attempts in which the call for heat is not satisfied, the burner controller will go into burner fault lockout mode. ■ If the call for heat is satisfied, the recycle counter resets. |

This procedure continues on the next page.

Continued from the previous page.

Fault modes The burner controller fault modes are described below.

| | |
|---------------------------|---|
| <p>Lockout</p> | <p>The burner will enter the lockout mode after three unsuccessful attempts to re-light the flame. During the lockout mode:</p> <ul style="list-style-type: none"> ■ The burner will not fire. ■ The diagnostic light on the burner controller will flash in half-second intervals. ■ The burner fault light on the control panel will illuminate. <p>To clear the lockout fault so a restart can be attempted, press and release the reset button. Note: <i>After the third attempt to manually clear the lockout fault, the burner controller will enter the restricted lockout mode.</i></p> |
| <p>Restricted lockout</p> | <p>The burner will enter the restricted lockout mode after three unsuccessful attempts to manually reset the lockout fault. During the restricted lockout mode:</p> <ul style="list-style-type: none"> ■ The burner will not fire. ■ The diagnostic light on the burner controller will flash in half-second intervals. ■ The burner fault light on the control panel will illuminate. <p>To clear the restricted lockout fault so a restart can be attempted, press and hold (approximately 30–45 seconds) the reset button until the diagnostic light flashes once. Note: <i>The burner will return to the lockout mode with each unsuccessful burner restart, until a successful heating cycle has occurred.</i></p> |

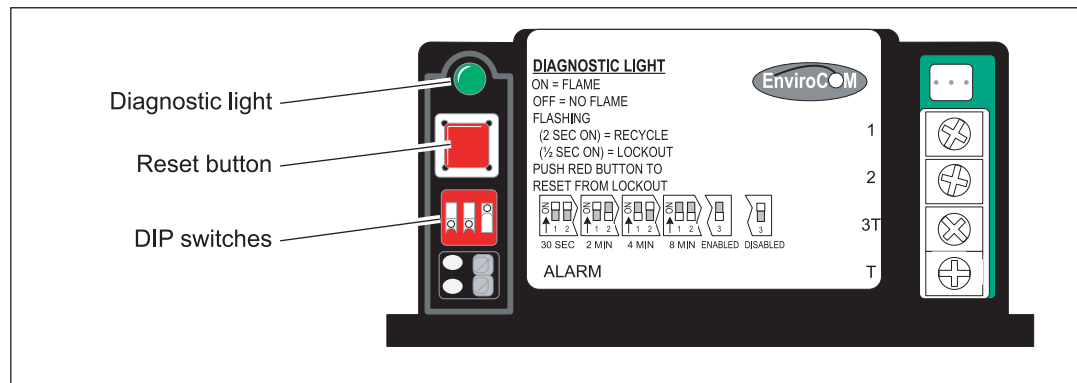

ghi_gr006221

5 Accessories

5.1 Available Accessories

To increase the machine's capabilities and capacities, the following Wacker Neuson accessories are available.

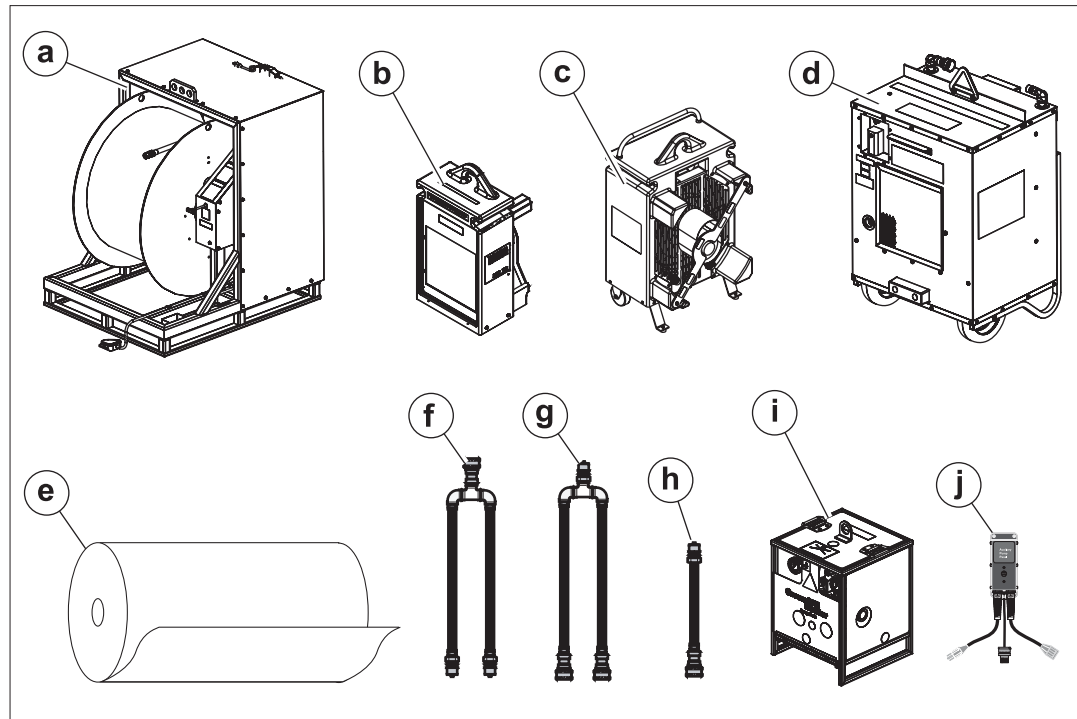

ghi_gr006475

| Ref | Description | Ref. | Description |
|-----|--------------------------------|------|--|
| a | Hose Handling System (HHS3002) | f | 1-2 Adapter |
| b | HEAT XCHANGER™ (HX 50) | g | 2-1 Adapter |
| c | HEAT XCHANGER™ (HX 100) | h | Accessory hoses (various lengths) |
| d | HEAT XCHANGER™ (HX 200) | i | Single (SPP) or Dual Pump Pack (DPP) |
| e | Insulation blanket | j | Auxiliary Pump Panel (APP) (power adapter) |

Configurations These accessories allow the following application configurations:

- Combining your parent machine with Heat XCHANGERS allows it to heat air.
- Combining your parent machine with a DPP and HHS increases the ground heating, thawing, and curing capacities of the parent machine.
- Covering the heat transfer hoses with insulation blankets increases heat retention and penetration.
- The 1–2 and 2–1 adapters and accessory hoses allow the accessories to be properly connected to your parent machine.

For compatibility and configuration information, continue reading.

5.2 Connecting the HX 200 or HX 60 HEAT XCHANGER™

- Requirements**
- Machine stopped
 - One HEAT XCHANGER (HX 60 or HX 200)
 - Hose: 2 pieces of 5/8-in. ID or 1-in. ID with quick-connect fittings

- Limitations**
- Maximum run (horizontal distance from HX to machine): 228 m (750 ft)
 - Maximum rise (vertical distance of HX above machine): 76 m (250 ft)
 - Maximum run at maximum rise: 215 m (707 ft)

Note: *The farther the HX is positioned from the parent machine, the more heat will be lost through the hose. This may affect HX performance.*

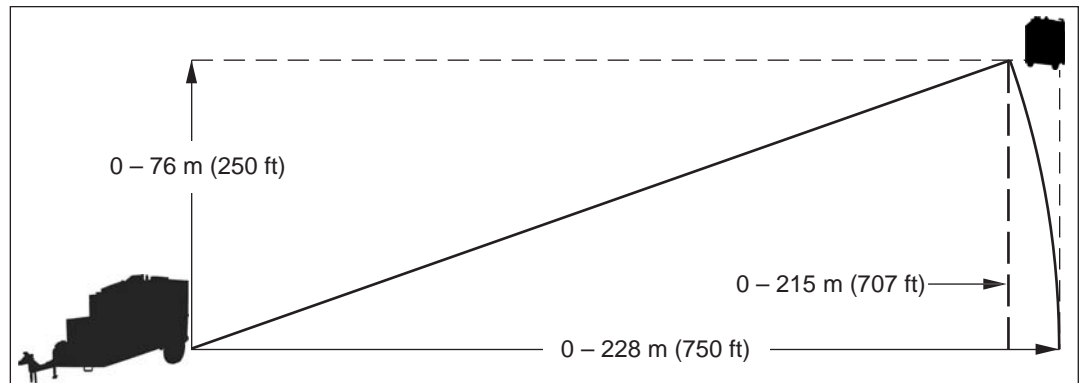

NOTICE: Disconnect both surface heating hose loops before connecting the HEAT XCHANGER. The HEAT XCHANGER requires all HTF flow from both pumps to perform at its rated capacity.

- Procedure**
- Perform the procedure below to connect the HEAT XCHANGER to the machine.
1. Stop the parent machine temporarily.
 2. Disconnect both surface heating hose loops from the machine before connecting the HEAT XCHANGER.

This procedure continues on the next page.

Continued from the previous page.

3. Open valve **(4)**.

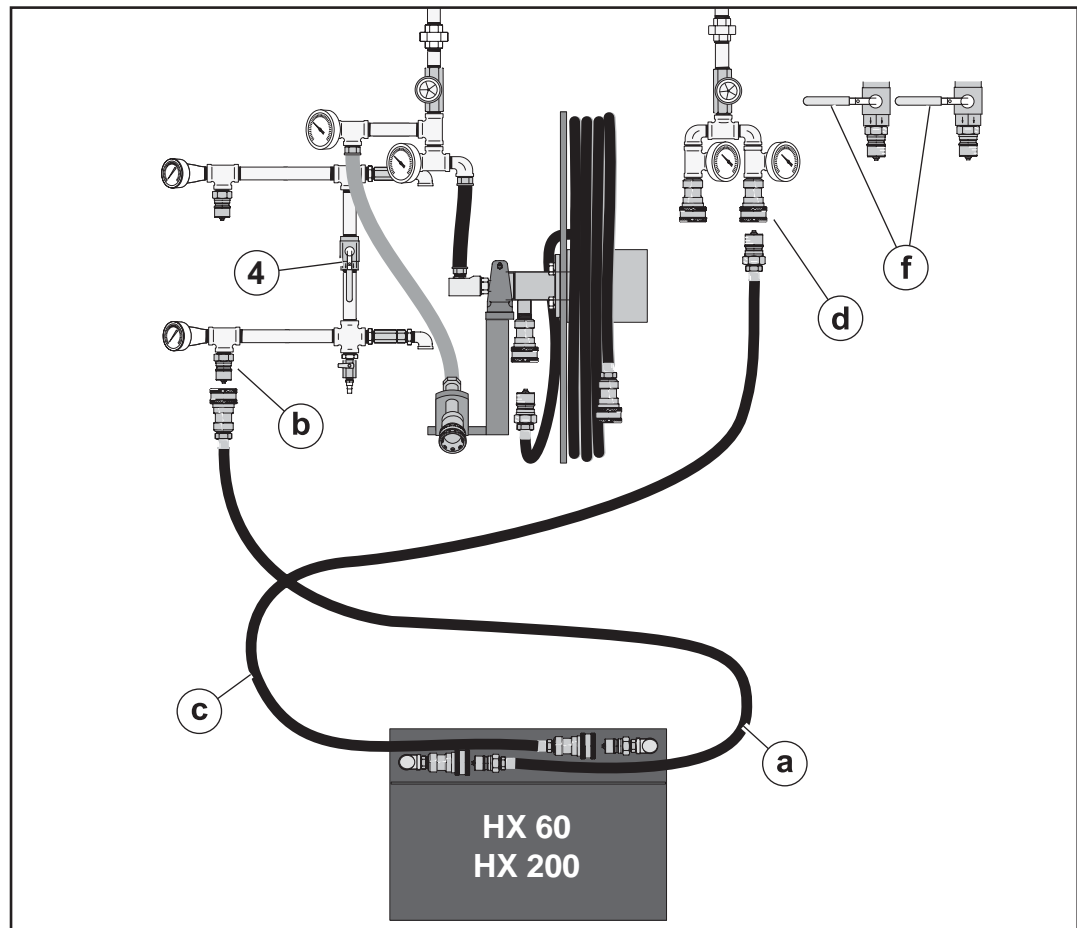

wc_gr007814

4. Position the HEAT XCHANGER within the space to be heated.
5. Connect the HEAT XCHANGER supply hose **(a)** to the HTF supply line **(b)**.
6. Connect the HEAT XCHANGER HTF return hose **(c)** to the accessory HTF return port **(d)**.
7. Insulate the supply and return hoses.
8. Close the Pump Pack HTF supply valves **(f)**.
9. Connect the HEAT XCHANGER to the appropriate electrical source.

NOTICE: Only turn on the pumps when the HEAT XCHANGER is connected. Turning on the pumps when the HEAT XCHANGER is not connected will cause excess system pressure which will damage the pumps.

10. Start the parent machine. Operate the parent machine with the temperature controller set to 80°C.
11. Turn on the HEAT XCHANGER and adjust its thermostat as desired.

Result

The HEAT XCHANGER has now been connected and is operating.

5.3 Connecting the HX 100 or HX 30 HEAT XCHANGER™

- Requirements**
- Machine stopped
 - One HEAT XCHANGER (HX 100 or HX 30)
 - Hose: For runs longer than 12 m (40 ft), 2 pieces of 5/8-in. ID with quick-connect fittings

- Limitations**
- Maximum run (horizontal distance from HX to machine): 228 m (750 ft)
 - Maximum rise (vertical distance of HX above machine): 76 m (250 ft)
 - Maximum run at maximum rise: 215 m (707 ft)

Note: *The farther an HX is positioned from the parent machine, the more heat will be lost through the hose. This may affect HX performance.*

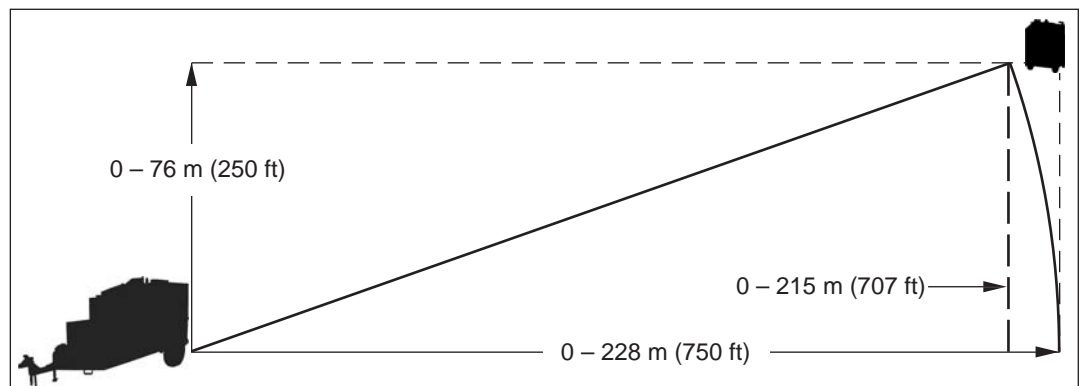

wc_gr008096

NOTICE: Disconnect both surface heating hose loops before connecting the HEAT XCHANGERS. The HEAT XCHANGERS require all HTF flow from both pumps to perform at their rated capacity.

Procedure Perform the procedure below to connect the HEAT XCHANGER to the machine.

1. Stop the parent machine temporarily.
2. Disconnect both surface heating hose loops from the machine before connecting the HEAT XCHANGERS.

This procedure continues on the next page.

Continued from the previous page.

3. Close valve **(4)**.

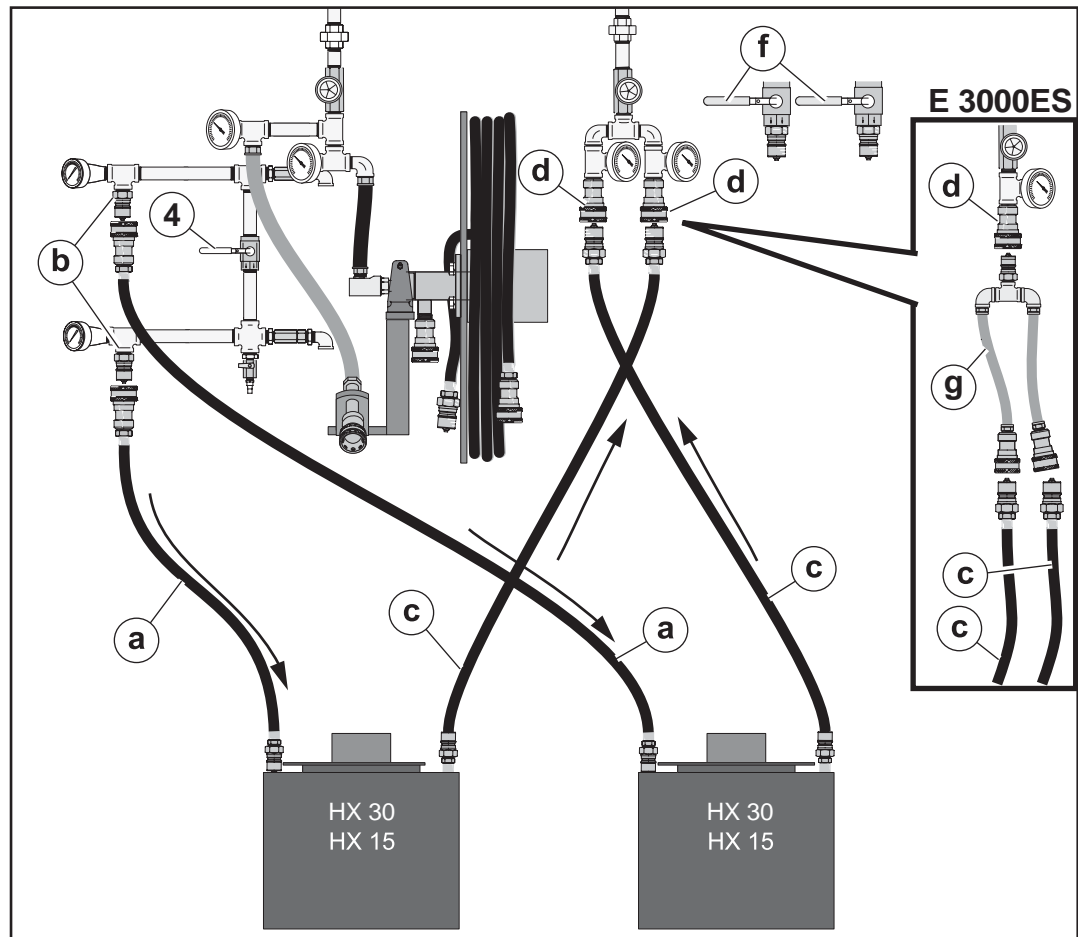

wc_gr007817

4. Position the HEAT XCHANGERS within the space to be heated.
 5. Connect the HEAT XCHANGER supply hoses **(a)** to the HTF supply line **(b)**.
 6. Connect the HEAT XCHANGER return hoses **(c)** to the accessory HTF return port **(d)**. On E 3000ES machines, use a 1–2 connector **(g)**.
 7. Insulate the supply and return hoses.
 8. Close the Pump Pack HTF supply valves **(f)**.
 9. Connect the HEAT XCHANGERS to the appropriate electrical sources.
- NOTICE:** Only turn on the pumps when the HEAT XCHANGERS are connected. Turning on the pumps when the HEAT XCHANGERS are not connected will cause excess system pressure which will damage the pumps.
10. Start the parent machine. Operate the parent machine with the temperature controller set to 80°C (180°F).
 11. Turn on the HEAT XCHANGERS and adjust their thermostats as desired.

Result

The HEAT XCHANGERS have now been connected.

5.4 Connecting the HX 50 or HX 15 HEAT XCHANGER™

- Requirements**
- Machine stopped
 - One HEAT XCHANGER (HX 50 or HX 15)
 - Hose: For runs longer than 12 m (40 ft), 2 pieces of 5/8-in. ID with quick-connect fittings

- Limitations**
- Maximum run (horizontal distance from HX to machine): 228 m (750 ft)
 - Maximum rise (vertical distance of HX above machine): 76 m (250 ft)
 - Maximum run at maximum rise: 215 m (707 ft)

Note: *The farther an HX is positioned from the parent machine, the more heat will be lost through the hose. This may affect HX performance.*

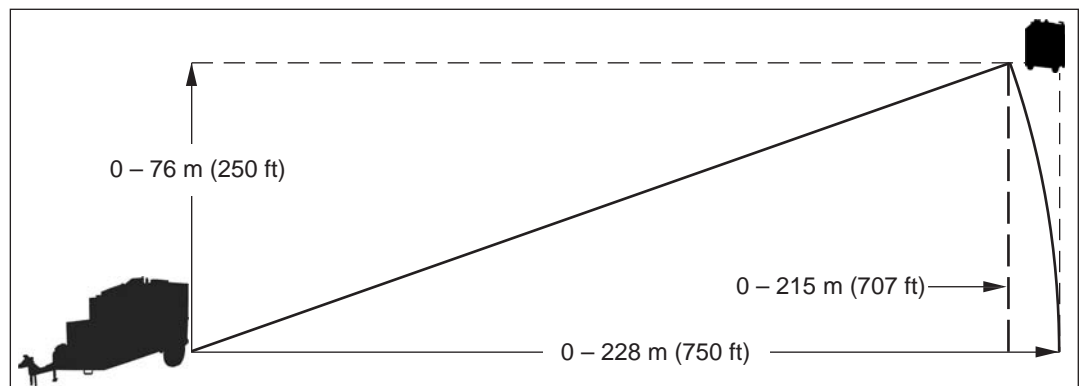

wc_gr008096

NOTICE: Disconnect both surface heating hose loops before connecting the HEAT XCHANGERS. The HEAT XCHANGERS require all HTF flow from both pumps to perform at their rated capacity.

Procedure Perform the procedure below to connect the HEAT XCHANGER to the machine.

1. Stop the parent machine temporarily.
2. Disconnect both surface heating hose loops from the machine before connecting the HEAT XCHANGERS.

This procedure continues on the next page.

Continued from the previous page.

3. Close valve **(4)**.

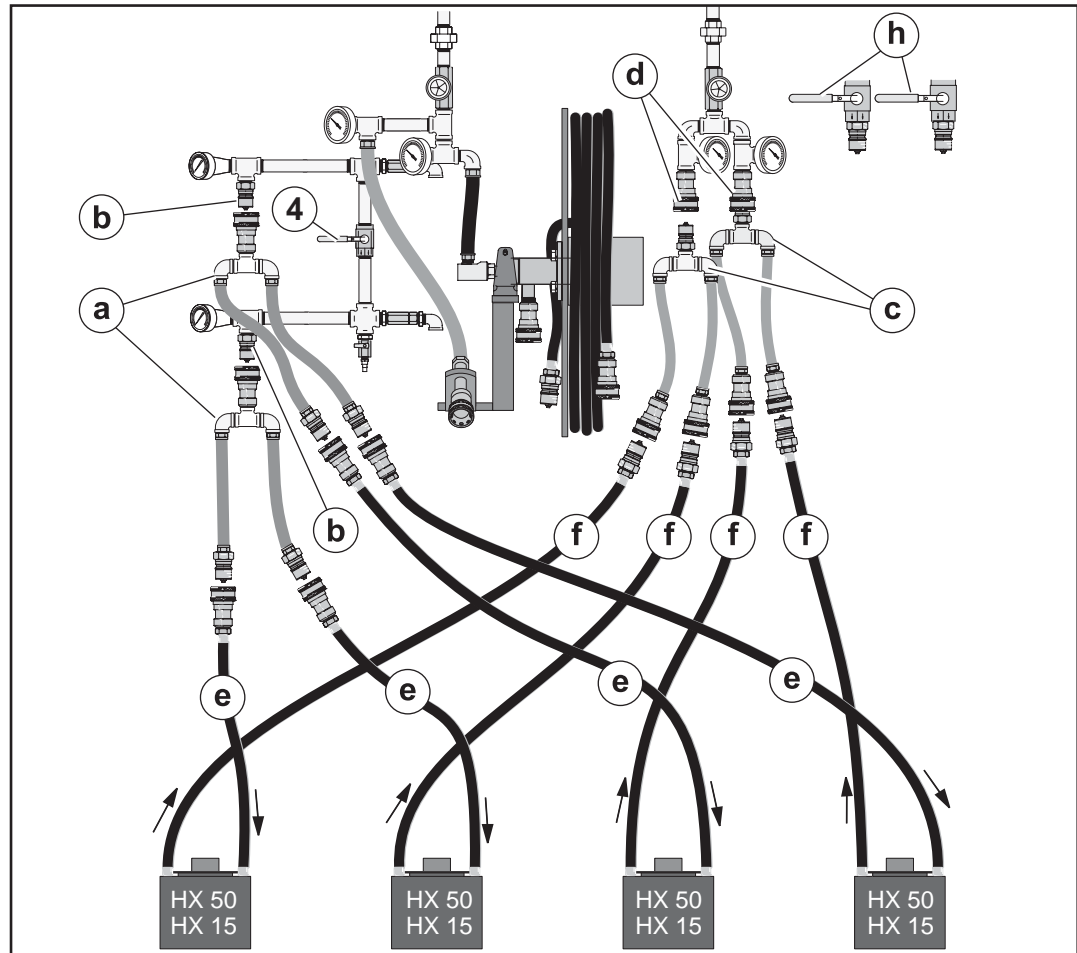

wc_gr007818

4. Position the HEAT XCHANGERS within the space to be heated.
5. Connect the 1-2 adapters **(a)** to the supply lines **(b)**.
6. Connect the HEAT XCHANGER supply hoses **(e)** to the 1-2 adapters **(a)**.
7. Connect the HEAT XCHANGER HTF return hoses **(f)** to 2-1 adapters **(c)**.
8. Close the Pump Pack HTF supply valves **(h)**.
9. Insulate the supply and return hoses.
10. Connect the HEAT XCHANGERS to the appropriate electrical sources.

NOTICE: Only turn on the pumps when the HEAT XCHANGERS are connected. Turning on the pumps when the HEAT XCHANGERS are not connected will cause excess system pressure which will damage the pumps.

11. Start the parent machine. Operate the parent machine with the temperature controller set to 80°C.
12. Turn on the HEAT XCHANGERS and adjust their thermostats as desired.

Result

The HEAT XCHANGERS have now been connected.

5.5 Combining the Machine with One HHS and One DPP

- Requirements**
- Machine stopped
 - Hose Handling System (HHS)
 - Dual Pump Pack (DPP)

Procedure Perform the procedure below to connect an HHS and a DPP to the machine.

1. Unwind and position the hose of the parent machine as normal **(x)**.
2. Position the HHS and the DPP **(e)** near the machine.

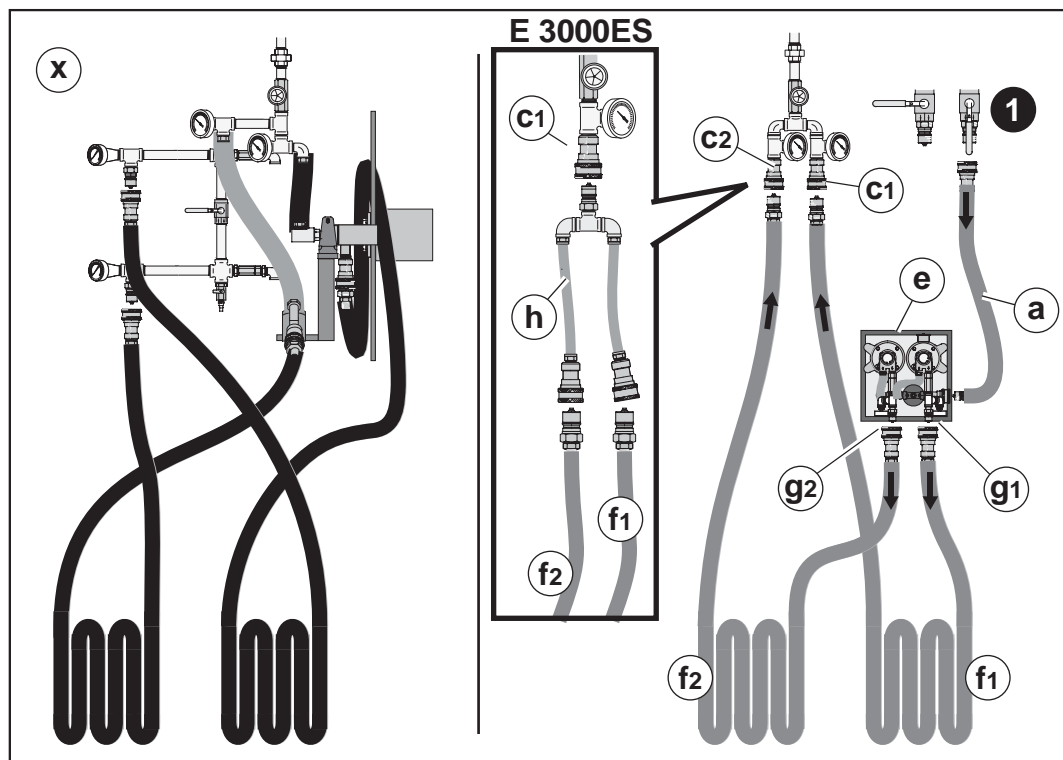

wc_gr007819

3. Connect the DPP supply hose **(a)** to accessory supply valve **(1)**. Then, open accessory supply valve **(1)**.

HHS Hose Loop 1

1. Connect HHS hose loop 1 **(f₁)** to the accessory return line **(c₁)**. On E 3000ES machines, use a 2-1 adapter **(h)**.
2. Unwind HHS hose loop 1 and position it within the application area.
3. Disconnect HHS hose loop 1 from HHS hose loop 2.
4. Connect HHS hose loop 1 **(f₁)** to a discharge port **(g₁)** of the DPP.

HHS Hose Loop 2

1. Connect HHS hose loop 2 **(f₂)** to the other accessory return line **(c₂)**.
2. Continue to unwind HHS hose loop 2 and place HHS hose loop 2 within the application area.
3. Remove hose loop 2 from the HHS and store the HHS in a secure location.
4. Connect HHS hose loop 2 **(f₂)** to the other discharge port **(g₂)** of the DPP.

Electrical connections

Make the following electrical connections.

Connect the power cord from the DPP (e) to the auxiliary receptacle labeled "PUMP PACK" (b).

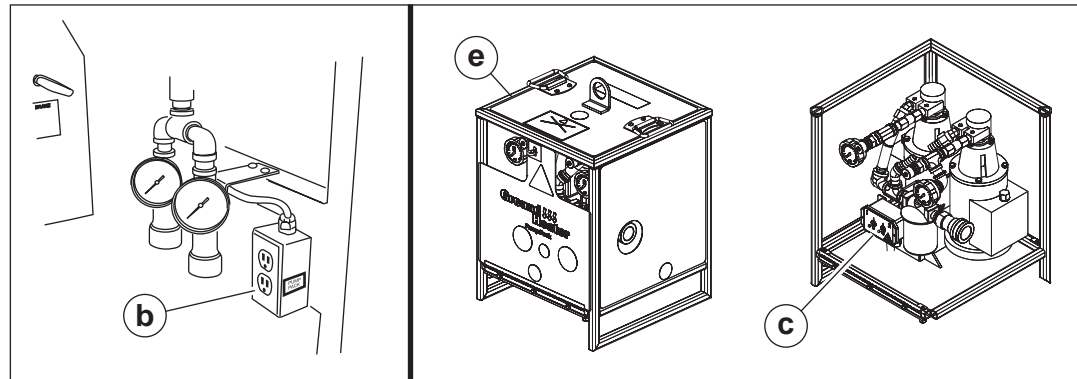

wc_gr008081

Operating

1. Start the parent machine. Turn on the burner and the pumps.
2. Start the pumps of the DPP, one at a time (c).
3. Monitor the HTF flows, pressures, and temperature as the machine operates.

5.6 Combining the Machine with Two HHS and Two DPP (E 2200 only)

- Requirements**
- Machine stopped
 - Two Hose Handling Systems (HHS)
 - Two Dual Pump Packs (DPP)
 - Two 2–1 adapters
 - One Auxiliary Pump Panel (APP). See topic *Mounting the Auxiliary Pump Panel*

Procedure Perform the procedure below to connect two HHS and two DPP to the machine.

4. Unwind and position the hose of the parent machine as normal (x).

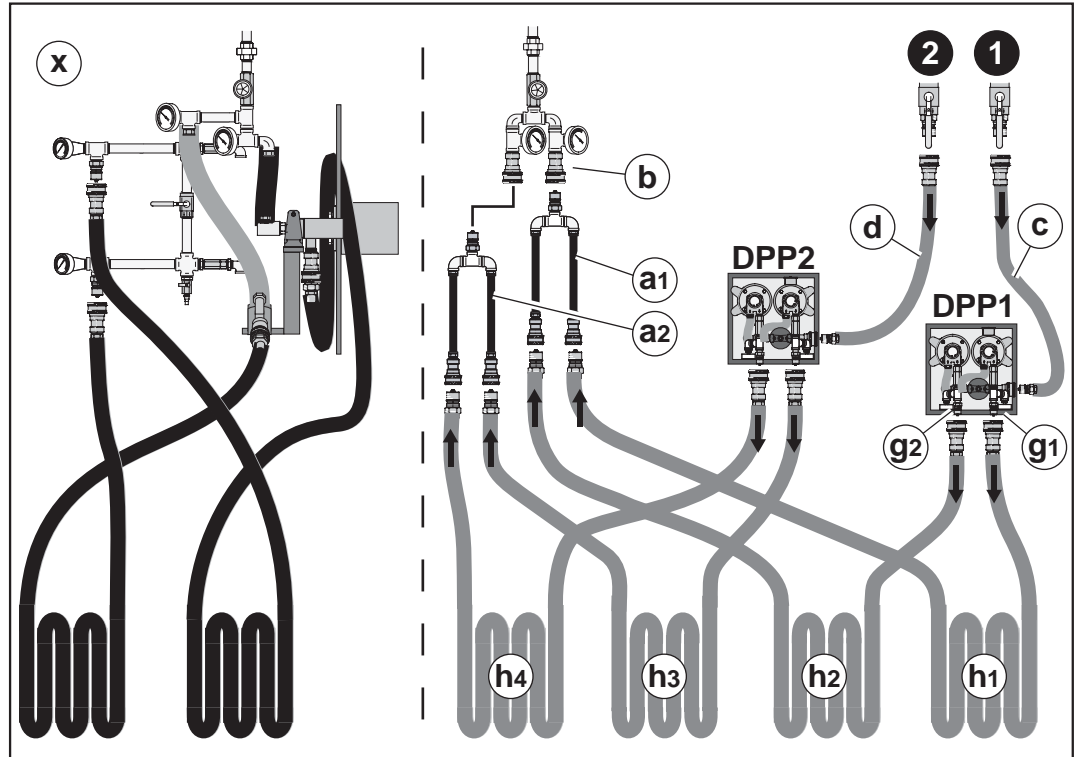

wc_gr008082

5. Connect both 2 – 1 adapters (**a₁** and **a₂**) to the return ports (**b**).
6. Position the Hose Handling Systems and the Dual Pump Packs near the machine.
7. Connect the DPP1 supply hose (**c**) to accessory supply valve (**1**). Then, open accessory supply valve (**1**).

HHS 1 Hose Loop 1

1. Connect HHS hose loop 1 (**h₁**) to adapter (**a₁**).
2. Unwind the HHS hose loop 1 and position it within the application area.
3. Disconnect HHS hose loop 1 from HHS hose loop 2.
4. Connect HHS hose loop 1 to a discharge port (**g₁**) of the DPP1.

HHS 1 Hose Loop 2

1. Connect HHS hose loop 2 (**h₂**) to adapter (**a₁**).
2. Continue to unwind HHS hose loop 2 and place HHS hose loop 2 within the application area.

3. Remove hose loop 2 from the HHS and store the HHS in a secure location.
4. Connect HHS hose loop 2 (**h₂**) to discharge port (**g₂**) of DPP1.

DPP 2 and HHS 2

Connect the hoses from HHS 2 to the machine and to DPP 2 in the same manner as connecting DPP 1.

Electrical connections

Make the following electrical connections.

1. Connect the power cord from the DPP1 (**m**) to the auxiliary receptacle labeled "PUMP PACK".

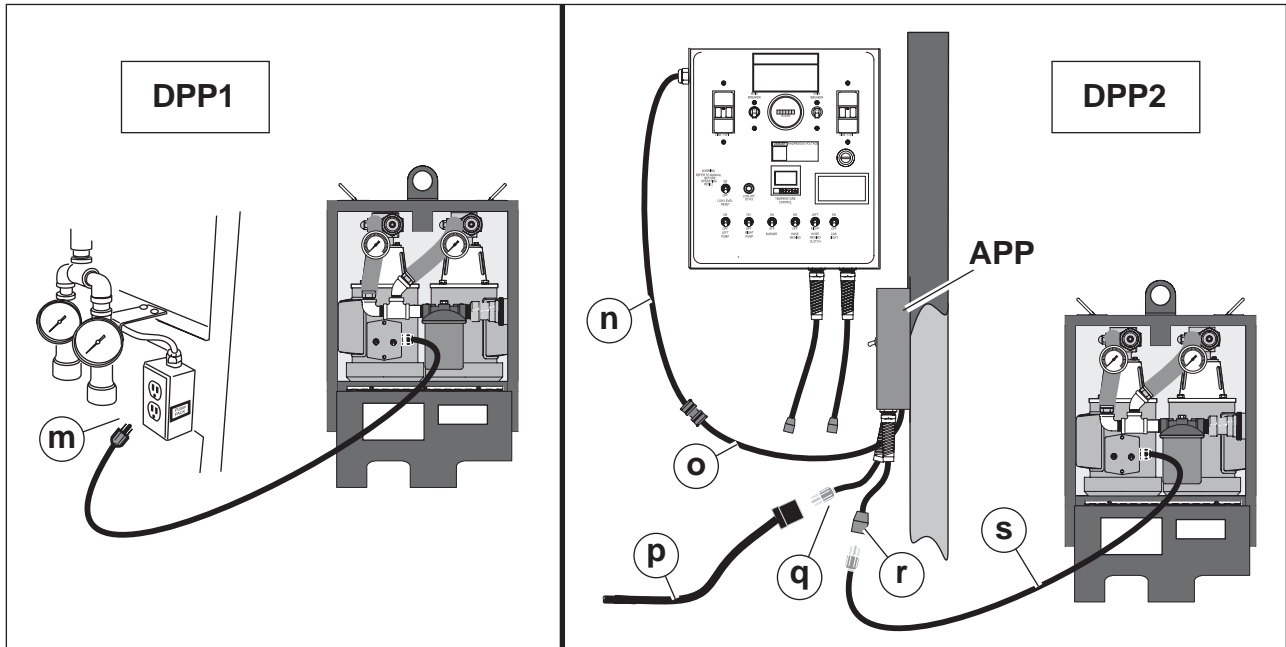

wc_gr008072

2. Connect the DIN leader (**n**) from the main control panel to the corresponding DIN leader on the APP (**o**).
3. Connect a properly-rated extension cord (**p**) to the power cord (**q**) on the APP.
4. Connect the Pump Pack power cord (**s**) to the APP power adapter (**r**).

Operating

1. Start the parent machine. Turn on the burner and the pumps.
2. Place the ON-OFF switch of the APP in the ON position.
3. Start the pumps of both DPPs, one at a time.
4. Monitor the HTF flows, pressures, and temperature as the machine operates.

5.7 Mounting the Auxiliary Pump Panel

- Requirments**
- Machine shut down
 - Power disconnected
 - Auxiliary Pump Panel

Background The Wacker Neuson Auxiliary Pump Panel (APP) is an electrical device that communicates with the main machine's systems to provide protection for any additional Pump Packs that are connected to the machine. If the machine experiences a low level fault condition, the APP will cut off power to the external components. This power cut-off protects the pumps from damage.

- Guidelines** Follow the guidelines below when mounting the APP. Refer to the diagram below.
- Install the APP inside the machine, near the main control panel **(a)**.
 - Install APP using included hardware **(b)**.

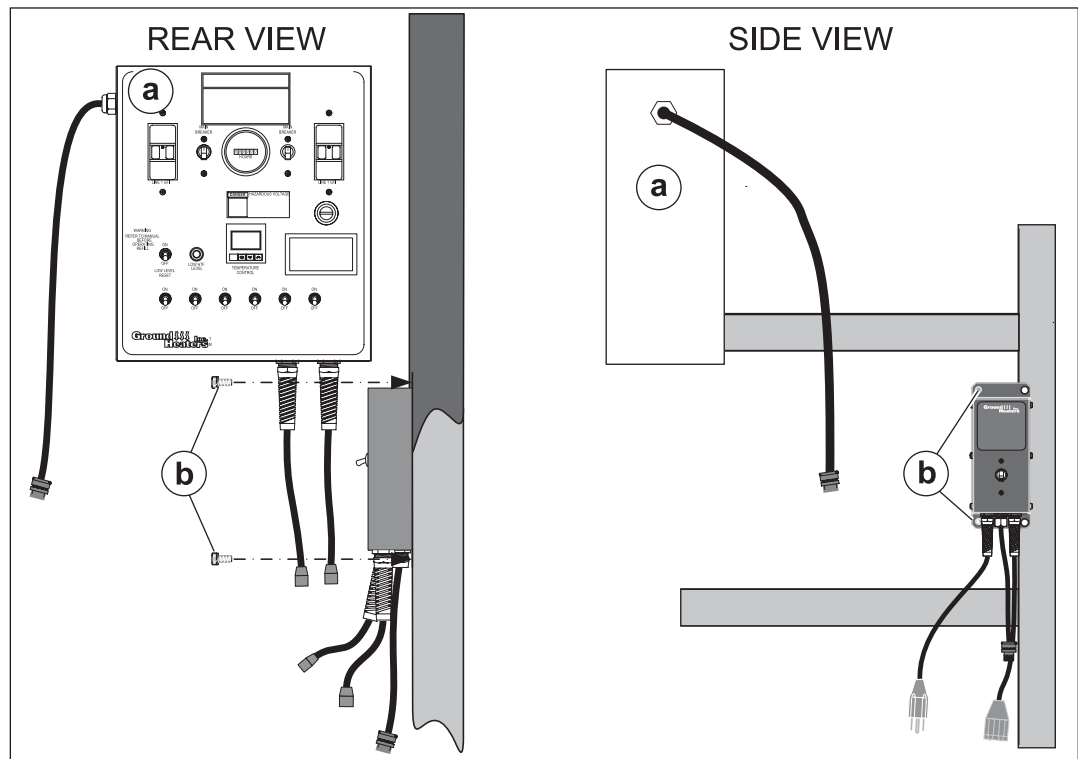

ghi_gr006489

6 Burner Setup

Factory settings

| Head | Firing rate L/hr (gph) | Nozzle size | Fuel pressure bar (psi) | Air band setting | Air shutter | Adjusting plate |
|------|---------------------------|----------------|----------------------------|---------------------|----------------|--------------------|
| V1 | 6.8 (1.80) | 1.35 70° B | 12.4 (180) | 1 | 10 | 5 |

Background The burner consists of several different components and subsystems. Each of these components or subsystems must be operating correctly for the burner to function properly.

Fuel Low ambient temperatures cause diesel fuels to gel. Gelled fuels will cause burner ignition failure and/or burner fuel pump damage. Always use the proper fuel for the conditions.

| Fuel Blend Guide | | |
|---|--|---|
| Lowest expected ambient temperature °F (°C) | Generator powered | Shore powered |
| Below 5 (-15) | 50-50 blend of #2 diesel and #1 diesel, plus additives OR 50-50 blend #2 diesel and K1 kerosene, plus additives | 100% #1 diesel plus additives OR 100% K1 kerosene, plus additives |
| 5 to 25 (-15 to -4) | 70-30 blend of #2 diesel and #1 diesel, plus additives OR 70-30 blend of #2 diesel and K1 kerosene, plus additives | |
| Above 25 (-4) | Winter-blend diesel | |

Tools required The following tools are required to adjust the burner:

- High-quality combustion analyzer
- Smoke spot tester
- Fuel pressure test gauge
- General hand tools

Mandates

- Adjustments must be made so that the machine conforms to the requirements of local, state, and federal codes and authorities.
- Adjustments shall be made at the job site.

This procedure continues on the next page.

Continued from the previous page.

When

Adjust the burner:

- Before operating the machine at elevations 305 m (1,000 ft) above or below the location of the previous adjustments
- Before starting at a new job site
- After any burner maintenance or repair has been performed
- If burner performance is in question

Procedure

Follow the procedure below to set up the burner.

1. Shut down the machine.
2. Set the burner electrodes.
 - ▶ (See topic 6.1 *Adjusting the Burner Electrodes.*)
3. Check the burner nozzle.
 - ▶ (See topic 6.2 *Replacing the Burner Nozzle.*)
4. Check/set the "Z" distance.
 - ▶ (See topic 6.3 *Setting the "Z" Distance*)
5. Set the air settings.
 - ▶ (See topic 6.4 *Adjusting the Air Settings.*)
6. Start the machine and the burner.
7. Check/set the fuel pressure.
 - ▶ (See topic 6.5 *Setting the Fuel Pressure.*)
8. Conduct a smoke spot test. Follow the smoke spot tester manufacturer's instructions and the general guidelines below.



ghi_gr006184

- Use the access hole in the exhaust stack.
- Several samples should be taken as the heater warms.
- The final sample should be taken just before the heater reaches 71°C (160°F).

This procedure continues on the next page.

Continued from the previous page.

- Analyze the combustion. Follow the combustion analyzer manufacturer's instructions and the general guidelines below.



ghi_gr006183

- Use the access hole in the exhaust stack.
 - Take several samples as the heater warms.
 - Take the final sample just before the heater reaches 71°C (160°F).
- Re-adjust the air setting(s) if necessary until the smoke spot test and combustion analysis are within the following parameters:
 - O₂ content: 4–6%
 - Smoke spot: 1 or less

Result

You have now set up the burner.

6.1 Adjusting the Burner Electrodes

- Requirements**
- Power supplies disconnected
 - Measuring device

Procedure Follow the procedure below to check the electrodes.

1. Shut down the machine and disconnect the power supplies.
2. Remove the copper fuel line **(a)** between the fuel pump and the burner housing.
Note: Only remove the fuel fitting closest to the burner housing.

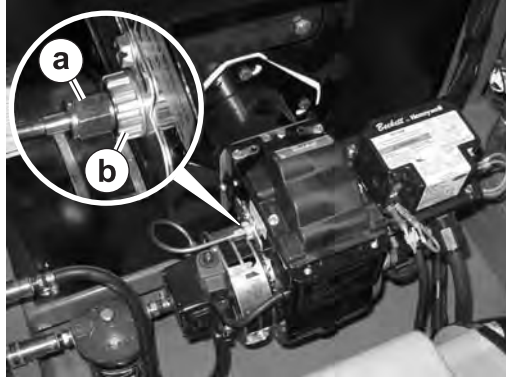

ghi_gr005524

3. Remove the splined nut **(b)** that is seated against the escutcheon plate.
NOTICE: Handle the splined nut with care. It is easily damaged.
4. Loosen tabs **(c)** and hinge back the igniter cover.

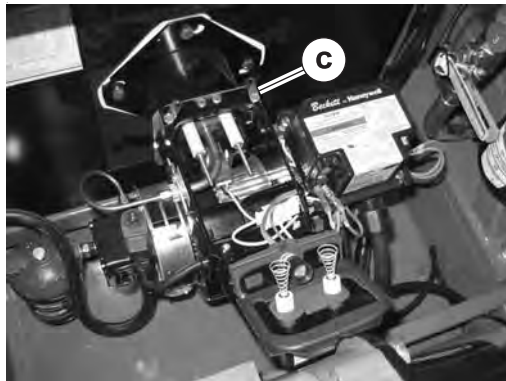

wc_gr008113

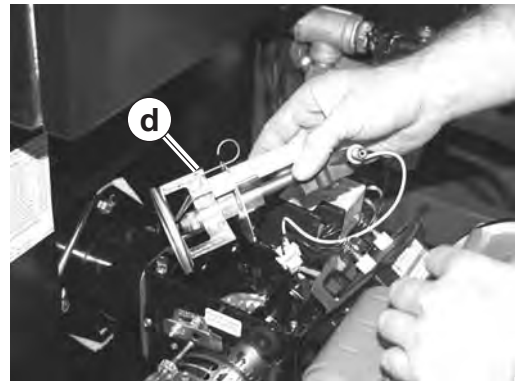

wc_gr008112

5. Disconnect the wiring to the electrode assembly.
6. Maneuver the electrode-nozzle assembly **(d)** up and out of the burner.

This procedure continues on the next page.

Continued from the previous page.

7. Use the measurements below to properly set the electrode tips.

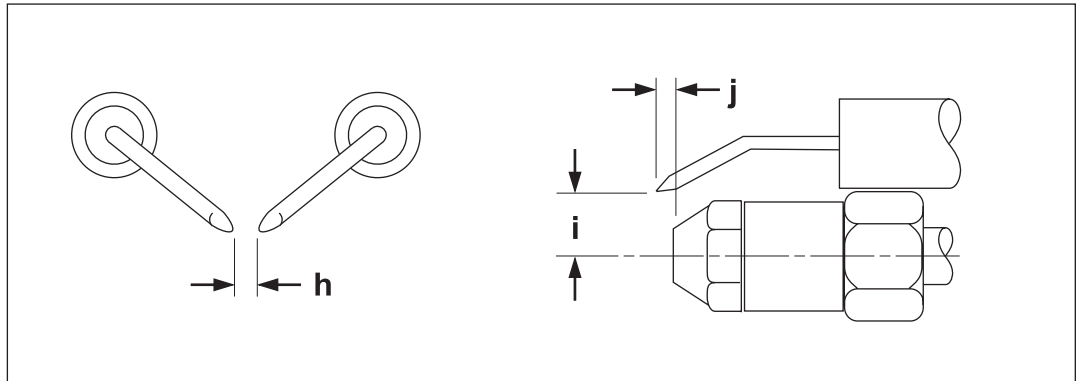

ghi_gr005523

| Ref. | Description | Gap distance |
|------|---------------------------------|-------------------|
| h | Electrode tip to electrode tip | 5/32 in. (4 mm) |
| i | Nozzle center to electrode tip | 5/16 in. (7.5 mm) |
| j | Nozzle end to electrode tip end | 1/16 in. (1.5 mm) |

Installation

Follow the procedure below to install the burner nozzle.

1. Thread the new burner nozzle into the burner tube.
Note: Do not use thread sealant on the threads.
2. Position the electrode-nozzle assembly (d) into the burner.

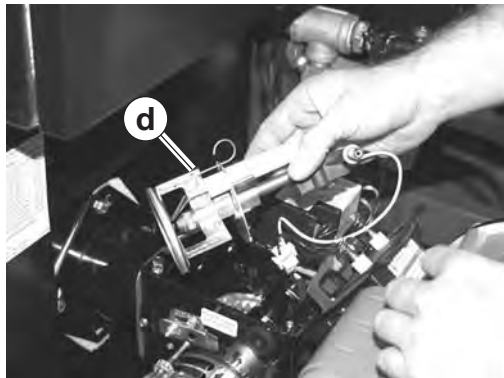

wc_gr008112

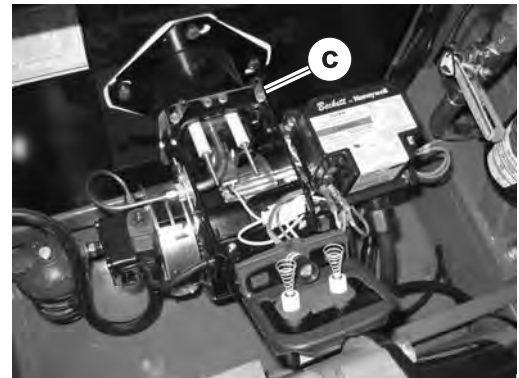

wc_gr008113

3. Connect the wiring.
4. Close the igniter cover and secure it with tabs (c).

This procedure continues on the next page.

Continued from the previous page.

5. Install the splined knob **(b)**.

Note: Handle the knurled knob with care. It is easily damaged.

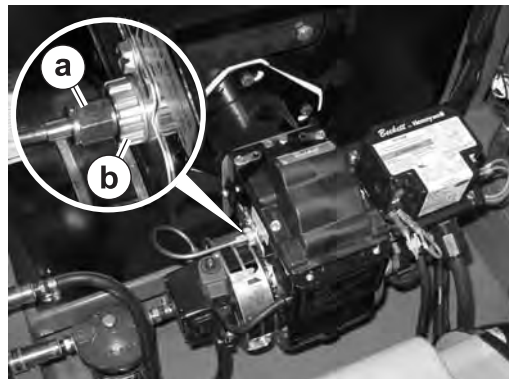

ghi_gr005524

6. Install the copper fuel line **(a)** between the fuel pump and the burner housing.

Result

The electrodes have now been checked/adjusted.

6.2 Replacing the Burner Nozzle

- Prerequisites**
- Power supplies disconnected
 - Machine cool

Removal

Follow the procedure below to remove the burner nozzle.

1. Disconnect the power supplies.
2. Remove the copper fuel line **(a)** between the fuel pump and the burner housing.

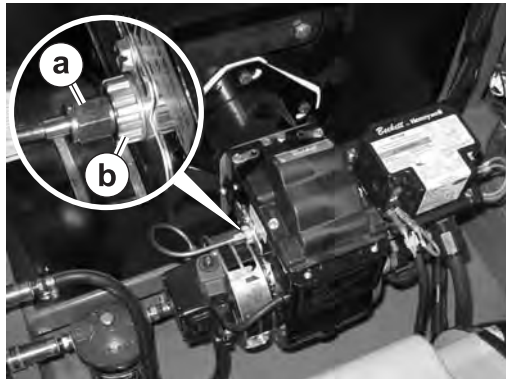

ghi_gr005524

3. Remove the splined knob **(b)** that is seated against the escutcheon plate.
Note: Handle the splined knob with care. It is easily damaged.
4. Loosen tabs **(c)** and hinge back the igniter cover.

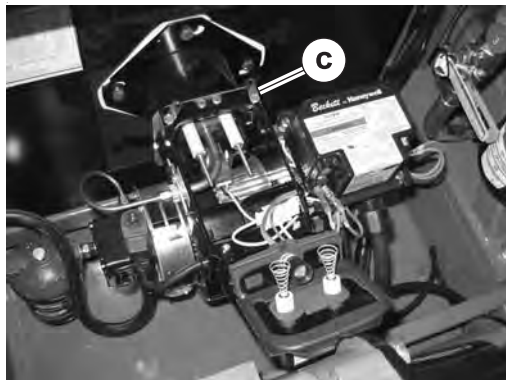

wc_gr008113

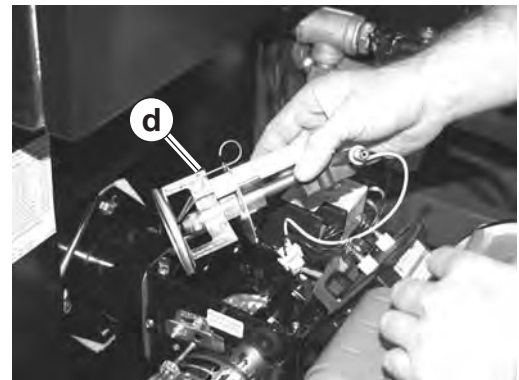

wc_gr008112

5. Disconnect the preheater wiring.
6. Maneuver the electrode-nozzle assembly **(d)** up and out of the burner.

This procedure continues on the next page.

Continued from the previous page.

7. Unscrew the burner nozzle **(e)** from the burner tube.

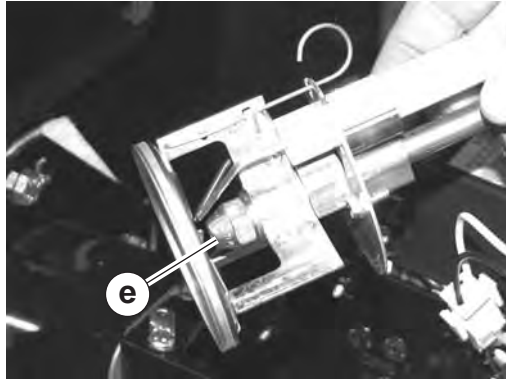

wc_gr008114

The procedure to remove the burner nozzle is now complete.

Installation

Follow the procedure below to install the burner nozzle.

1. Thread the new burner nozzle into the burner tube.
Note: *Do not use thread sealant on the threads.*
2. Position the electrode-nozzle assembly **(d)** into the burner.

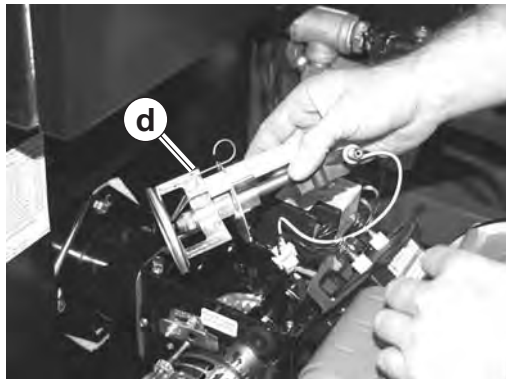

wc_gr008112

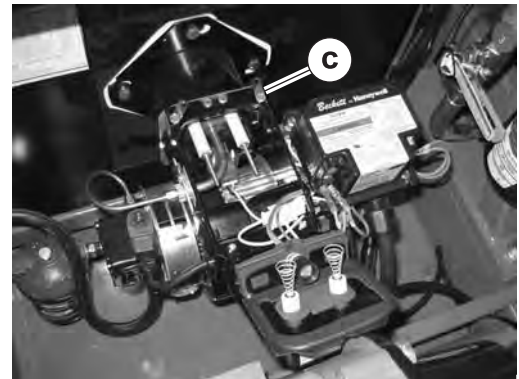

wc_gr008113

3. Connect the wiring.
4. Close the igniter cover and secure it with tabs **(c)**.

This procedure continues on the next page.

Continued from the previous page.

5. Install the splined knob **(b)**.

Note: Handle the knurled knob with care. It is easily damaged.

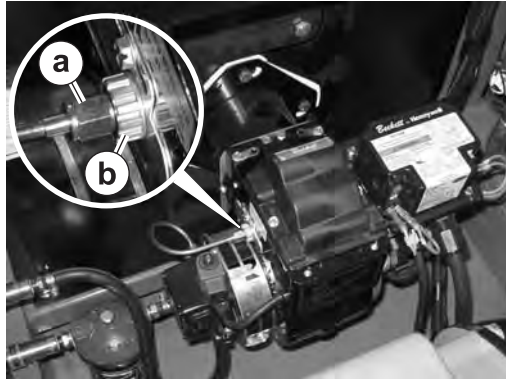

ghi_gr005524

6. Install the copper fuel line **(a)** between the fuel pump and the burner housing.

Result

The burner nozzle has now been replaced.

6.3 Setting the “Z” Distance on V1-Style Heads

- Requirements**
- Burner removed from the machine
 - T501 gauge or straight edge and measuring device

Preliminary steps

Follow the procedure below to set the “Z” distance on V1-style heads.

1. Remove the burner from the machine.
2. Disconnect the copper fuel line from the nozzle assembly.
3. Loosen the splined nut **(a)**.

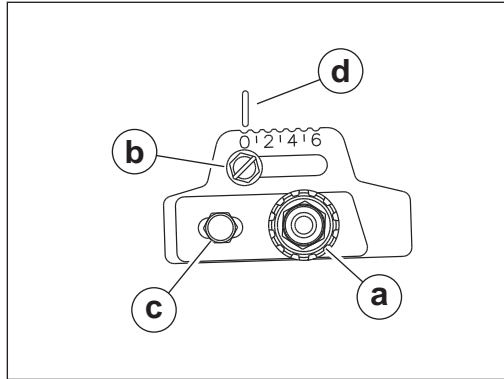

wc_gr008105

4. Loosen the hex head screw **(b)**.
5. Loosen the acorn nut **(c)**.
6. Move the head adjusting plate until “0” lines up with the indicator **(d)** on the housing. Tighten the hex head screw **(b)**.
7. Set the “Z” distance. See below.

“Z” distance

Perform the procedure below to measure the “Z” distance.

1. Place a straight edge **(x)** on the end of the air tube.

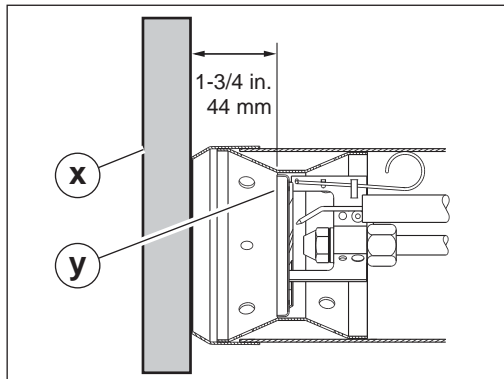

wc_gr008103

2. Adjust the nozzle assembly until the distance between the end of the head **(y)** and end of the air tube is 1-3/4 inches (44 mm).
3. Tighten the acorn nut.

This procedure continues on the next page.

Continued from the previous page.

4. Tighten the hex head screw.
5. Tighten the splined nut.
6. Reconnect the oil connector tube.

Result

The “Z” distance has now been set.

Continue by setting the head position adjusting plate.

Set the head position

Perform the procedure below to set the head position adjusting plate.

1. Loosen the hex head screw **(b)**.

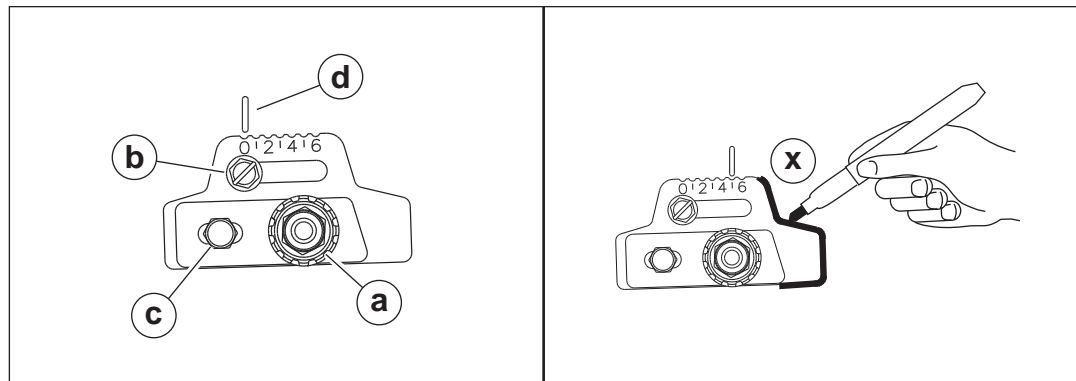

wc_gr008106

2. Loosen the splined nut **(a)**. Do not loosen acorn nut **(c)**.
3. Move the nozzle assembly until the burner reference indicator **(d)** lines up with the number listed in the *Factory Settings* chart in topic *Burner Setup*.
4. Tighten both the hex head screw and the splined nut.
5. Mark **(x)** the head position adjusting plate for future reference.

6.4 Adjusting the Air Settings

Background There are two parts to adjusting the air setting: 1) air band; and 2) air shutter. Adjust the air band to make large adjustments. Adjust the air shutter to make small adjustments.

Effects The air setting has the following effects on combustion.

- Higher O₂ percentage (excess air settings) lowers soot production but raises stack temperature and reduces efficiency: lean mixture.
- Lower O₂ percentage (inadequate air settings) increases efficiency and lowers stack temperature but may cause soot build-up: rich mixture.

Procedure Follow the procedure below to adjust the air settings.

1. Initial setting of the air damper should be performed with the machine shut down.
2. Loosen the air band locking screw **(a)** and the air shutter locking screw **(b)**.

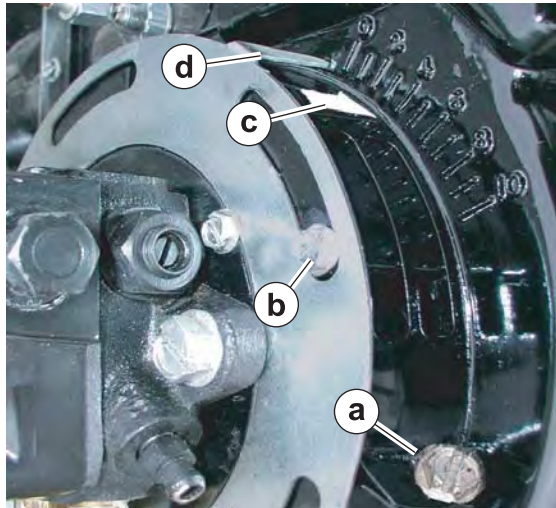

ghi_gr006189

3. Using the band position pointer **(c)** to determine position, move the air band to a higher number to increase air volume. Turn it to a lower number to decrease air volume.
 4. Using the shutter position pointer **(d)** to determine position, move the air shutter to a higher number on the shutter position pointer to increase air volume. Turn it to a lower number to decrease air volume.
 5. After the air settings have been made, tighten the band-locking screw **(a)** and the shutter-locking screw **(b)**.
-

Result You have now adjusted the air settings.

6.5 Setting the Fuel Pressure

- Requirements**
- Pressure gauge
 - See *Factory Settings* chart in topic *Burner Setup* for fuel pressure reading

Procedure Follow the procedure below to check and adjust the fuel pressure.

1. Shut down the machine.
2. Remove the bleeder valve **(a)** from the fuel pump.

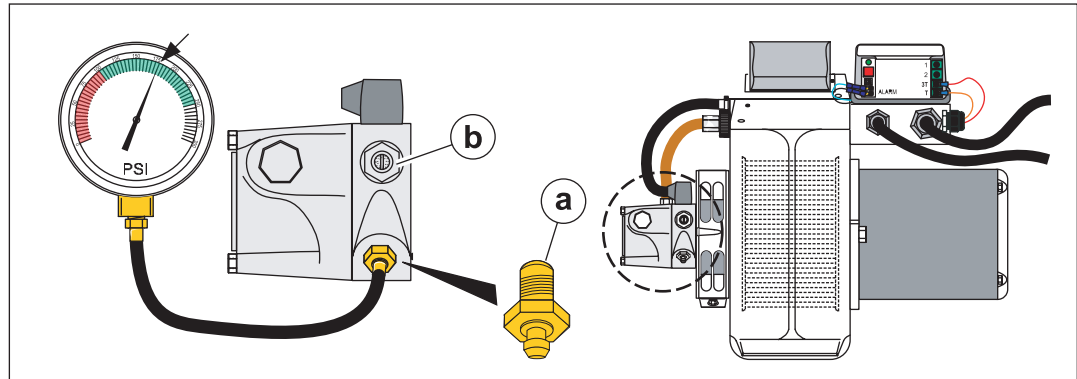

ghi_gr006188

3. Insert the gauge in place of the bleeder valve.
4. If your machine has a generator, start it.
5. Move the Burner ON-OFF switch to the ON position. The burner will go through a pre-purge cycle. Monitor and make adjustments during the pre-purge cycle.
6. Turn the adjusting screw **(b)** clockwise to increase fuel pressure, counterclockwise to decrease fuel pressure.

Result The fuel pressure has now been adjusted.

Notes

7 Maintenance

7.1 Periodic Maintenance Schedule

The table below lists basic machine maintenance. Tasks designated with check marks may be performed by the operator. Tasks designated with square bullet points require special training and equipment.

Refer to the generator manufacturer's operation manual for generator maintenance procedures.

| Task | Interval* (hours of service) | | |
|--|--------------------------------------|----------------|------------------|
| | Daily --- | 2 Week (50) | Yearly (1200) |
| Inspect hose couplings. | ✓ | | |
| Clean quick-connect couplings | ✓ | | |
| Inspect hoses and connectors. | ✓ | | |
| Inspect electrical cords/connections. | | ■ | |
| Check/adjust burner air setting. | | ■ | |
| Check HTF level. Fill if necessary. | | ✓ | |
| Check/adjust fuel pressure. | | ■ | |
| Check/adjust electrodes. | | | ■ |
| Replace burner nozzle. | | | ■ |
| Clean HTF strainer. | | | ■ |
| Replace fuel filter. | | | ■ |
| Lubricate hose reel chain. | | | ■ |
| Lubricate hose reel bearings. | | | ■ |
| Clean turbulator tubes. | | | ■ |
| Inspect rope gasket. | | | ■ |
| Test the burner exhaust and adjust the settings. | As needed or upon changing job sites | | |
| * Use whichever comes first, calendar time or service hours. | | | |

7.2 Repairing a Hose

- Requirements**
- Hose nipple
 - Two hose ferrules
 - Hose crimping tool, part number 0169002

Procedure Follow the procedure below to repair a damaged hose.

1. Shut down the machine and allow the Heat Transfer Fluid (HTF) to cool.
2. Locate the damaged portion of the hose and clamp locking pliers on either side of the damaged portion.
3. Cut away the damaged portion of the hose **(a)** using a utility knife or similar tool.

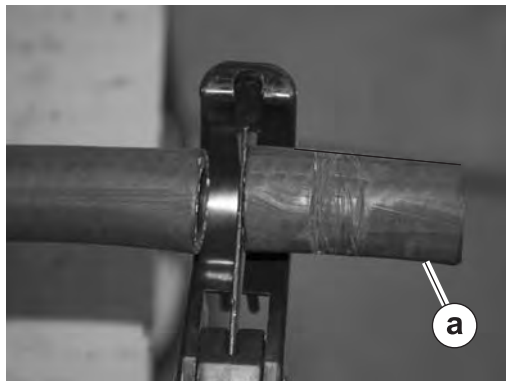

ghi_gr005622

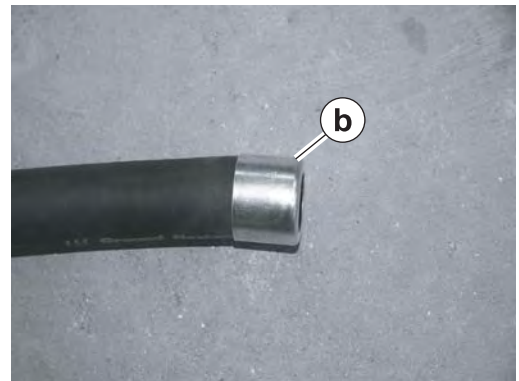

ghi_gr005623

4. Install a ferrule **(b)** on each end of the freshly cut hose.
5. Insert a nipple **(c)** into one of the ferrules.

NOTICE: Do not use petroleum to lubricate the nipple. If lubrication is needed, use HTF.

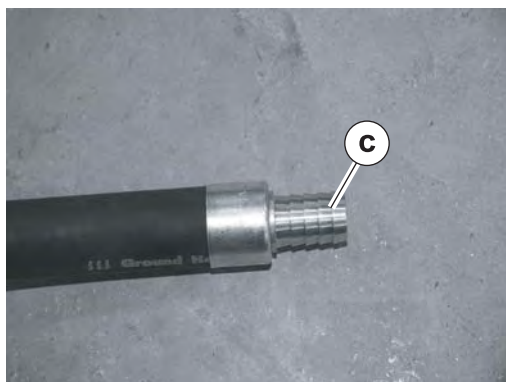

ghi_gr005624

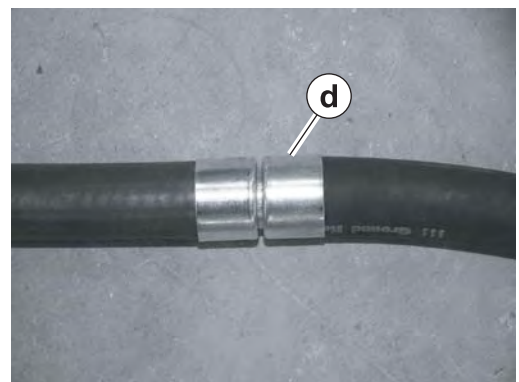

ghi_gr005625

6. Insert the free end of the nipple into the second ferrule. Be sure to push each end of each hose to the lip of the nipple.

This procedure continues on the next page.

Continued from the previous page.

7. Use a Wacker Neuson brand hose crimper **(e)** to crimp both ferrules.

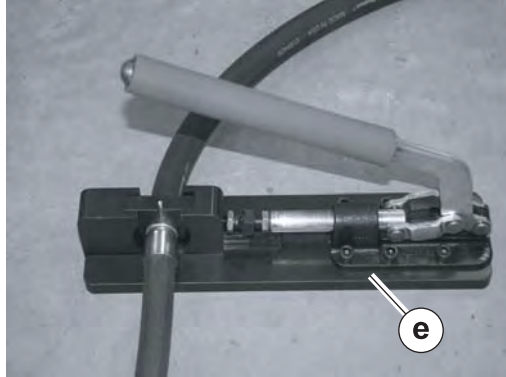

ghi_gr005626

8. Rotate the hose 90 degrees and crimp both ferrules again.

The procedure is now complete.

7.3 Inspecting the HTF System and the Fuel System

- Requirements**
- Machine shut down
 - Burner cool
-

HTF System

Hoses:

1. Rotate the hose reel brake T-handle counterclockwise to release the brake.
2. Unwind all the hose off the reel. Inspect the hose for leaks and/or damage.
3. Repair any leaks and repair/replace any damaged hoses. See topic *Repairing a Hose*.
4. Turn on the machine and rewind the hose onto the reel.
5. Engage the brake by turning the T-handle clockwise.

Pump, motor, and hydronic heater:

1. Inspect the pumps and motor assemblies and associated plumbing for leaks and/or damage.
 2. Inspect hydronic heater and associated plumbing for leaks and/or damage.
 3. Repair/replace any damaged components.
 4. Repair any leaks.
-

Fuel System

Burner:

1. Inspect all fuel hoses and connections for leaks and/or damage.
 2. Inspect the fuel filter and associated fuel hoses for leaks and/or damage.
 3. Repair/replace any damaged hoses, pipes, or connectors.
 4. Repair any leaks.
-

Fuel tank:

1. Inspect all fuel hoses running into and out of the fuel tank for leaks and/or damage.
2. Repair/replace any damaged hoses, pipes, or connectors.
3. Repair any leaks.

7.4 Inspecting Electrical Cords

- Requirements**
- Machine stopped
 - Circuit breaker off
 - All power disconnected from machine
-

- Procedure**
1. Open all access doors and remove all access covers.
 2. Inspect control panel and associated electrical cords for wear and/or damage.
 3. Inspect pump and associated electrical cords for wear and/or damage.
 4. Inspect hose reel and associated electrical cords for wear and/or damage.
 5. Inspect burner and associated electrical cords for wear and/or damage.
 6. Repair/replace any worn or damaged cords. Refer to your Parts Book for replacement parts.

7.5 Filling the HTF Reservoir

- Requirements**
- Genuine Wacker Neuson Heat Transfer Fluid
 - Machine is on a level surface

NOTICE: Use only factory-recommended Heat Transfer Fluid (HTF). Failure to comply may damage the machine.

Background The procedure for routine filling of the HTF reservoir differs slightly from that when a low level fault is encountered. If your machine has experienced a low level fault, see topic *Resetting a Low HTF Level Fault*.

Fill the HTF reservoir

1. Remove the pin and move the fill valve **(3)** to the OPEN position.

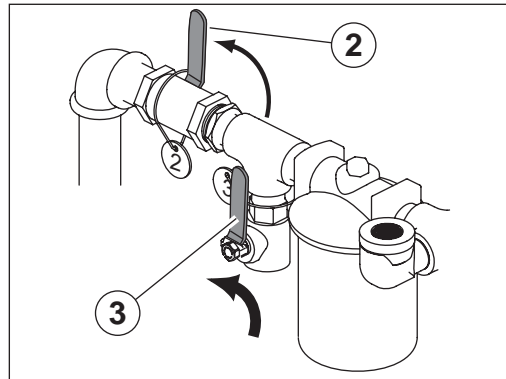

wc_gr007807

2. Move the operation valve **(2)** to the CLOSED position.
3. Remove the fill hose from its storage location under the hose reel. Remove the cap from the hose if a cap is provided.
4. Place the open end of the fill hose into a container of HTF.

This procedure continues on the next page.

Continued from the previous page.

Fill the HTF reservoir

5. Move and hold the bypass switch **(x)** in the ON position. HTF will begin to flow. When the HTF is level is between the minimum and maximum marks on the sightglass **(c)**:
 - a. Pull the fill hose from the HTF supply.
 - b. Release the bypass switch.

NOTICE: Do not overfill the HTF reservoir. Doing so may damage the machine.

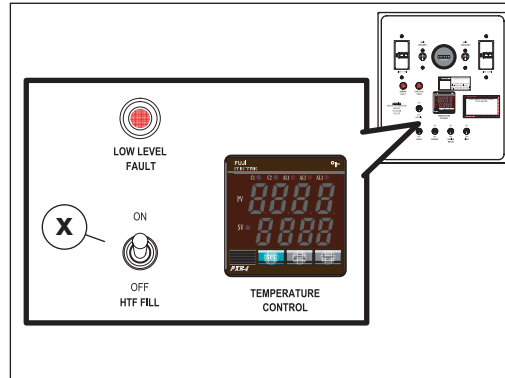

wc_gr008068

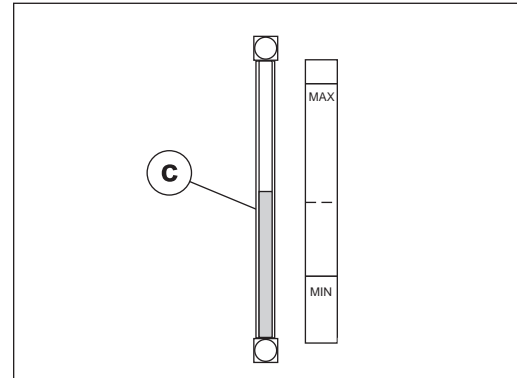

wc_gr008120

Prepare machine for operation

After filling the HTF reservoir, perform the procedure below to prepare the machine for operation.

1. Press the low-level shut-down reset button **(a)** if the red LED **(b)** is lit.

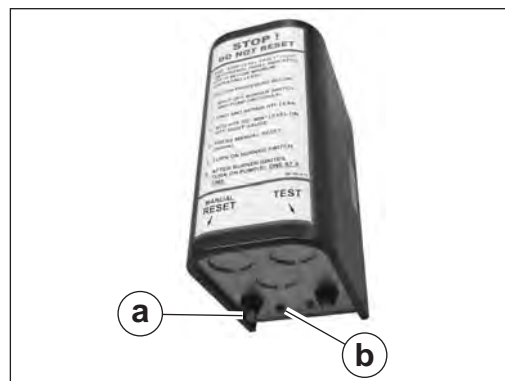

wc_gr008077

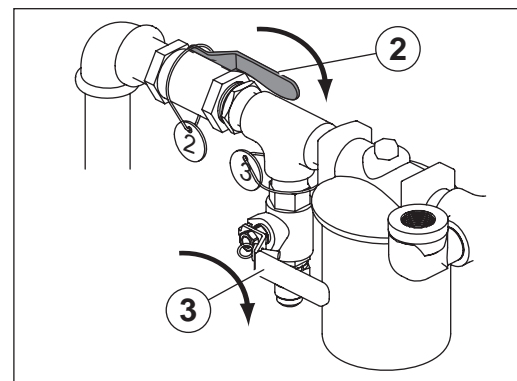

wc_gr007810

2. Move the operation valve **(2)** to the OPEN position.
3. Move the fill valve **(3)** to the CLOSED position and insert the pin.
4. Clean the fill hose, and cap the fill hose if a cap is provided.
5. Return the fill hose to its storage location under the hose reel.

Result

The machine is now ready for operation.

7.6 Cleaning the HTF Strainer

- Requirements**
- Machine shut down
 - Source of clean, warm water

Removal Perform the procedure below to clean the HTF strainer.

Note: *In the interests of environmental protection, place a plastic sheet and a container under the machine to collect any liquid which drains off. Dispose of this liquid in accordance with local environmental protection laws.*

1. Loosen, but do not remove, the top screw **(a)**.

Note: *There is a second screw **(b)** under the canister **(c)**. Hold this screw while loosening the screw **(a)**.*

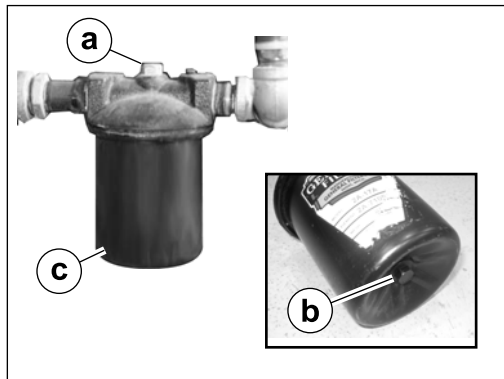

wc_gr007694

2. Tap on screw **(a)** with a hammer to release the gasket seal.
3. Remove the canister **(c)** by removing screw **(a)**—support the canister while doing so.
4. Dispose of the HTF that remains in the canister.
5. Remove the gasket **(d)** from the canister. Replace it if it is damaged.

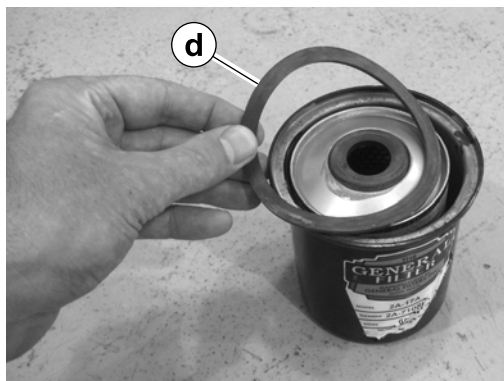

wc_gr007695



wc_gr007696

6. Remove the strainer basket **(e)** from the canister.
7. Rinse the strainer basket and the canister with clean, warm water.

This procedure continues on the next page.

Continued from the previous page.

Installation

1. Inspect the strainer gasket (**f**) and replace it if it is damaged.



wc_gr007697

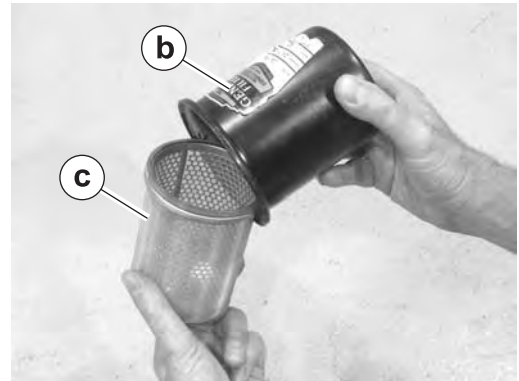

wc_gr007698

2. To ensure strainer gasket (**f**) placement, install the canister (**b**) over the strainer basket (**c**).
3. Install the gasket (**d**) to the canister.

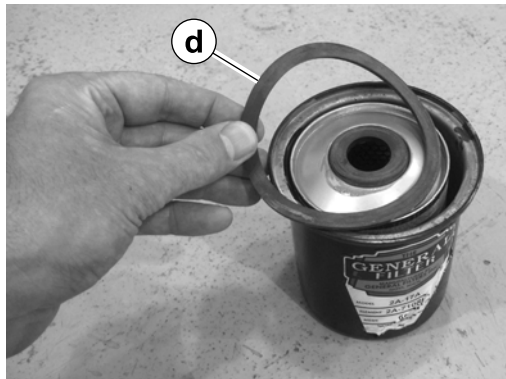

wc_gr007695

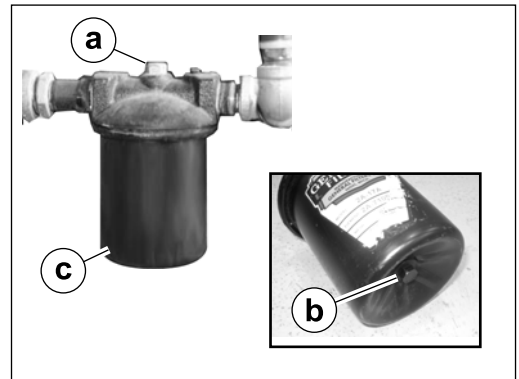

wc_gr007694

4. Install the strainer housing (including strainer basket) (**c**) into the machine using the screw (**a**) and screw (**b**).

Result

The HTF strainer is now clean and ready for operation.

7.7 Replacing the Fuel Filter

- Requirements**
- Machine shut down
 - New fuel filter element and gasket kit

Removal **NOTICE:** Do not remove the fuel filter assembly from the machine unless the filter housing cap needs to be replaced.

To remove the fuel filter element, carry out the following procedure.

Note: *In the interests of environmental protection, place a plastic sheet and a container under the machine to collect any liquid which drains off. Dispose of this liquid in accordance with local environmental protection laws.*

1. Disconnect the fuel line at the quick-connect fitting **(a)**.

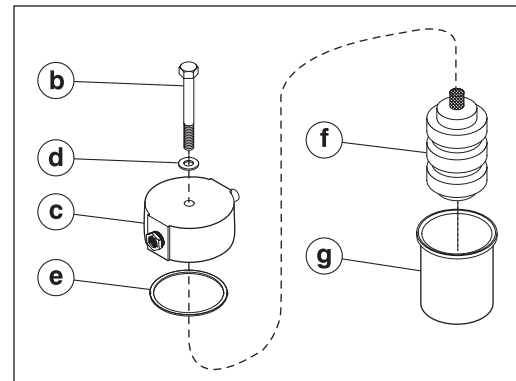
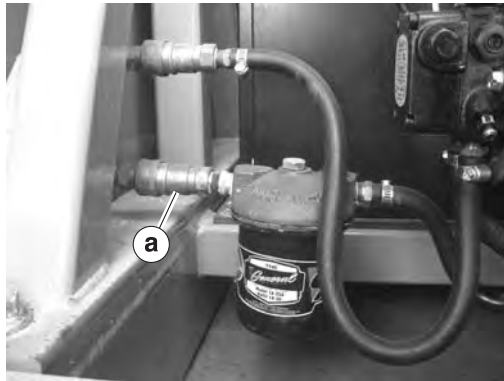

wc_gr008078

2. Loosen (do not remove at this time) the bolt **(b)** that secures the filter housing cap **(c)**.
3. Hold the filter housing **(g)** and lightly tap the bolt **(b)** with a hammer to break the seal between the gasket **(e)** and the housing **(g)**.
4. Remove the bolt **(b)** and gasket **(d)**.
5. Remove the filter housing cap **(c)** and gasket **(e)**.
6. Pull the fuel filter element **(f)** out of the housing.

Installation Perform the procedure below to install the new fuel filter.

1. Remove any remaining gasket material from the filter housing cap or the housing.
2. Place the new fuel filter element **(f)**, with exposed screen portion facing up, into the housing **(g)**.
3. Place the new gasket **(e)** on the top lip of the housing.
4. Slide the new gasket **(d)** on the bolt **(b)**.
5. Reinstall the filter housing cap **(c)** to the housing **(g)** with bolt **(b)**.
6. Reconnect the fuel line at the quick-connect fitting **(a)**.

Result The fuel filter has now been changed.

7.8 Lubricating the Hose Reel System

- Requirements**
- Machine shut down
 - Machine cool

Procedure Perform the procedure below to lubricate the hose reel system.

1. Disconnect electric power from the machine.
2. Apply low temperature bearing grease, with several pumps from a grease gun, to each bearing **(a)**.

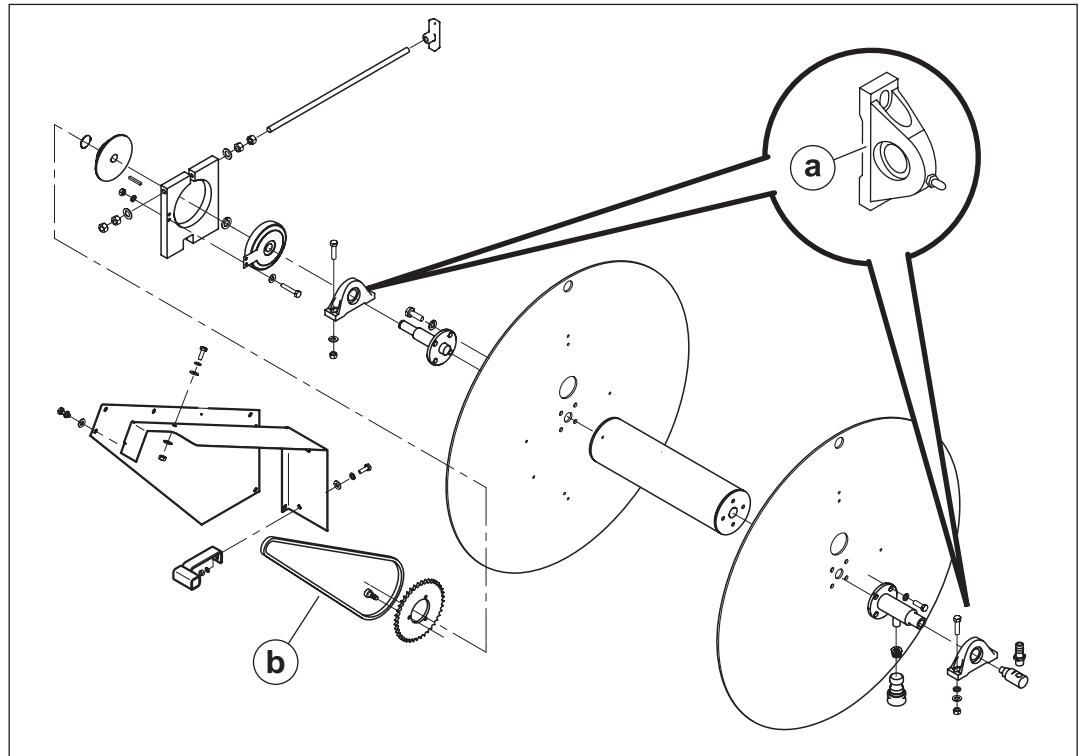

wc_gr007823

3. Lightly apply a low temperature lubricating oil to the chain **(b)**.

Result

The hose reel system has now been lubricated.

7.9 Cleaning the Turbulators and the Exhaust Ducting

- Requirements**
- Machine shut down
 - Machine cool

Procedure Follow the procedure below to clean/change the turbulator tubes.

1. Allow the machine to cool.



WARNING

Burn hazard. The hydronic heater is very hot when the machine is operating. When hot it can cause severe burns.

- ▶ Allow the machine to cool before performing this procedure.

2. Remove the nuts **(a)** that secure the flue box door.

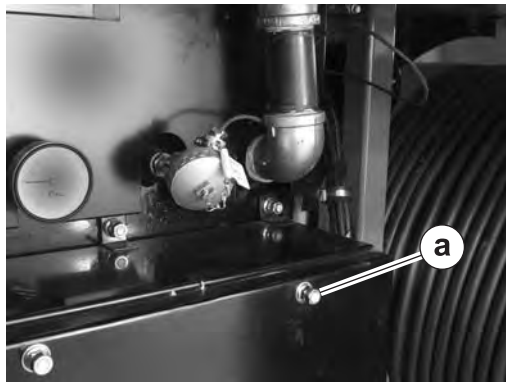

ghi_gr005628

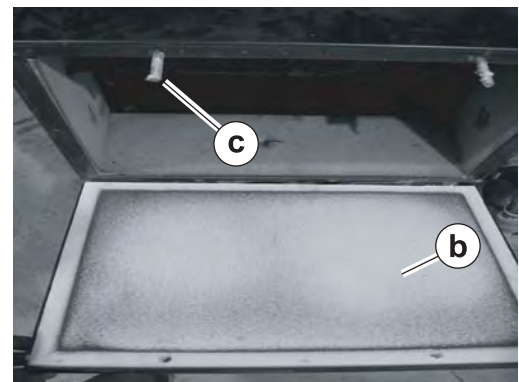

ghi_gr005627

3. Open the flue box door **(b)**.

NOTICE: If the door panel insulation does not open with the door, carefully remove it from where it is caught on the bolts **(c)**. Inspect all panels for damaged insulation. Replace all damaged panels.

4. Locate the turbulators housed in the burner tubes.

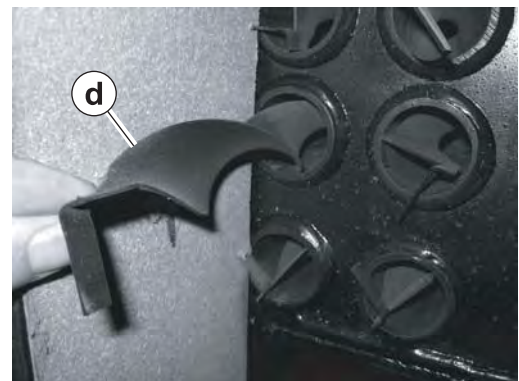

ghi_gr005629

5. Remove the turbulators **(d)** by pulling the turbulator tab. Replace any turbulator that is badly eroded.
6. Clean each burner tube with a bottle brush.
7. Vacuum out each burner tube.

- Remove the exhaust stack **(e)** (both inner and outer panels).

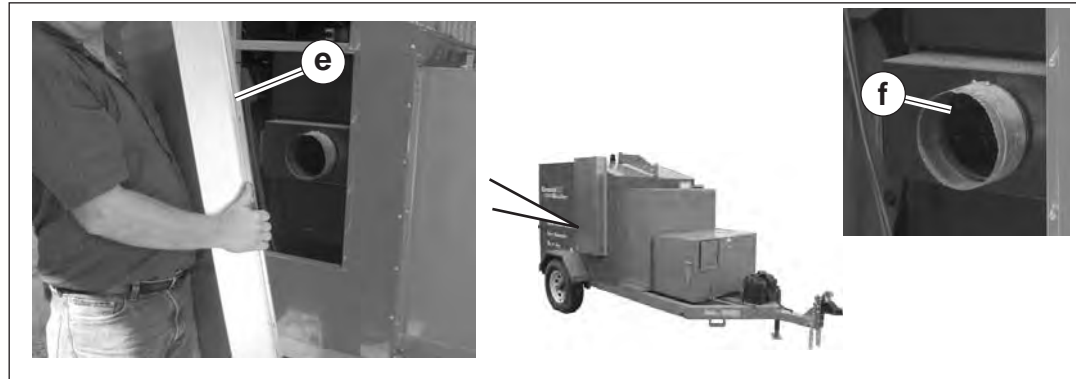

wc_gr008079

- Vacuum out the exhaust ducting **(f)** and the heater.

- Reinstall the exhaust stack.

- Reassemble the machine.

Result

The procedure is now complete.

7.10 Inspecting/Replacing the Rope Gasket

- Requirements**
- Machine shut down
 - Machine cool

Integrity inspection

Follow the procedure below to confirm the integrity of the flue box rope gasket.

1. Allow the machine to cool.



WARNING

Burn hazard. The hydronic heater is very hot when the machine is operating. When hot it can cause severe burns.

- ▶ Allow the machine to cool before performing this procedure.

2. Inspect the area around the flue box door **(a)** for the following signs of leakage.

- White or brown residue is visible.
- Rope gasket is protruding from flue box.
- Bubbles are visible on the black painted surface.

NOTICE: If any of these symptoms exist, investigate and repair the source.

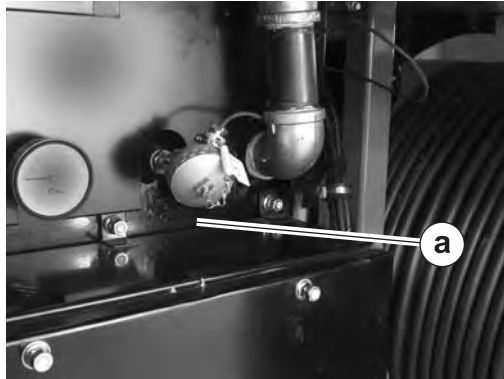

ghi_gr006509

Replace the rope gasket

Follow the procedure below to replace the rope gasket.

1. Remove the nuts **(b)** that secure the flue box door and remove the door.

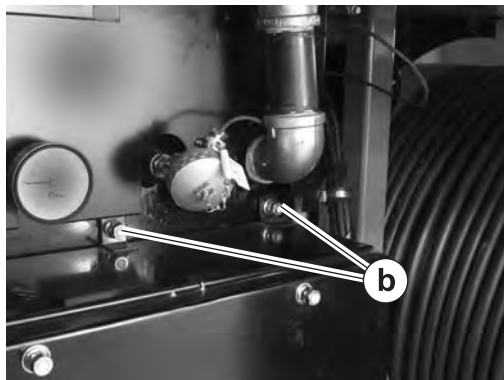

ghi_gr006510



ghi_gr006511

2. Remove the old gasket **(c)** and replace with a new one.

Note: You may need to use a tool (such as a screwdriver) to remove the gasket.

The procedure is now complete. Re-assemble the machine.

7.11 Storing the Machine

Short-term storage

1. Fill the HTF reservoir if it is low.
 2. Stop the machine. See topic *Shutting Down and Packing Up the Machine*.
 3. Remove and store any accessories.
 4. Allow the heater to cool sufficiently.
 5. Verify that all control switches are in the OFF position.
 6. Fill the fuel tank if it is low. Allow space in the fuel tank for fuel expansion.
-

Long-term storage

1. Fill fuel tank with stabilized fuel and operate the burner for at least fifteen minutes to ensure circulation through entire fuel system. Any brand of fuel stabilizer is acceptable.
2. Allow heater to cool sufficiently. Cover the chimney and the burner with plastic wrap or other waterproof material. This will prevent corrosive moisture build-up and blockages caused by animal nests.
3. Shut and lock all doors.
4. If the machine has a trailer, protect the trailer tires from direct sun light.
5. When removing from storage, the machine must be prepared for operation. See topic *Preparing the Machine for Seasonal Operation*.

7.12 Preparing the Machine for Seasonal Operation

Background After removing the machine from long-term storage, it must be prepared for operation. Perform the procedures below before each seasonal use.

Before powering up machine

Perform the procedures below before you power up the machine.

| Item | Task |
|---------------------|---|
| Machine exterior | Clean all outside surfaces |
| Heater and burner | <ul style="list-style-type: none"> ■ Remove protective coverings from chimney and burner. ■ Remove any carbon buildup from the heater and burner assemblies. ■ Replace the burner nozzle. ■ Verify burner electrode position. |
| Controls and wiring | <ul style="list-style-type: none"> ■ Inspect all wires for damage, corrosion, or wear. Replace damaged wiring. ■ Inspect all electrical components for damage, corrosion, or wear. Replace damaged electrical components. |
| HTF system | <ul style="list-style-type: none"> ■ Inspect all hoses and couplings for wear or damage. Replace damaged hoses and couplings. ■ Clean the HTF strainer basket. |
| Fuel system | Replace the fuel filter element. |

With machine powered up

Perform the procedures below with the machine powered up.

| Item | Task |
|--------|---|
| Burner | <ul style="list-style-type: none"> ■ Verify fuel pump pressure. ■ Verify burner combustion. |

Notes

8 Troubleshooting

8.1 Troubleshooting the Machine

| Problem / Symptom | Reason | Remedy |
|---|---|--|
| The burner does not start. | Improper switch position or protective function action. | Verify that the breaker is ON. Verify that the HTF level is within range and low level shutdown device is reset (low level indicator light must be OFF). |
| | The burner primary control is in lockout mode. | Reset the burner control. |
| | The over-temperature limit has tripped. | Reset the thermal switch. |
| The burner starts; the flame does not ignite. | There is no fuel. | Fill fuel tank. |
| | The burner nozzle is damaged or worn. | Replace the burner nozzle. |
| | The electrodes are defective. | Replace the electrodes. |
| | The cadmium cell is malfunctioning. | Replace the cadmium cell. |
| | The burner primary control is malfunctioning. | Replace the burner primary control. |
| The burner starts and the flame ignites, but does not stay lit. | The fuel pressure is set incorrectly. | Adjust the fuel pressure. |
| | The burner nozzle is damaged or worn. | Replace the burner nozzle. |
| | The air damper is set incorrectly. | Adjust the air damper. |
| | The cadmium cell is malfunctioning. | Replace the cadmium cell. |
| | The burner primary control is malfunctioning. | Replace the burner primary control. |
| Combustion is poor or noisy. | There is a lack of fresh air to burner. | Ensure there is an adequate air supply. |

| Problem / Symptom | Reason | Remedy |
|--|--|--|
| Thaw progress is below capacity. | The insulation is insufficient. | Add additional insulation blankets. |
| | The moisture is insufficient. | Verify that there is standing water on job site. |
| | There is no vapor barrier. | Lay down vapor barrier. |
| | The HTF is not flowing. | Verify that the pump pressure is nominal and hoses are not restricted. |
| | The temperature control is not set properly. | Set the temperature control to optimum setting. This setting depends on environmental conditions at the job site. |
| | The soil conditions are not as expected. | Re-evaluate thawing plan based on job site conditions. |
| Pump will not start. | There is no power. | Verify that the breaker switch is ON. Verify that the HTF level is within range and low level cutoff control is reset (low level indicator light must be OFF). |
| | The HTF temperature is below -26°C (-15°F). | Warm the HTF and hoses before turning on the pumps; see topic <i>Preheating the Heat Transfer Fluid (HTF)</i> in this manual. |
| Hose rewind does not work. | The hose reel brake is not fully released. | Fully release the hose reel brake. |
| | The motor temperature is below nominal value (<-18°C (0°F)). | Warm the enclosure by running the burner with all doors closed, or warm the enclosure using an external heat source. |
| | The foot pedal switch has failed. | Replace the foot pedal switch. |
| Pump is noisy and HTF flow is below nominal value. | The operation valve is not fully open. | Verify that the operation valve is fully open. |
| | The HTF temperature is below -26°C (-15°F). | Warm the HTF and hoses before starting machine; see topic <i>Preheating the HTF</i> in this manual. |
| | The strainer basket is clogged. | Clean the strainer basket; see topic <i>Cleaning the HTF Strainer</i> . |
| | Hose loops not separated. | Separate the hose loops. |

9 Technical Data

9.1 E 2200

| E 2200 | Units | Item No. 0620176 | Item No. 0620215 | Item No. 0620216 | Item No. 0620226 |
|---------------------------------|-----------------------------------|-----------------------------|-----------------------------|-----------------------------|-----------------------------|
| Weight, no fuel, no generator | kg (lb) | 2139 (4715) | | | |
| Weight, full fuel, no generator | kg (lb) | 2618 (5772) | | | |
| Generator weight | kg (lb) | n/a | n/a | 238 (525) | |
| Fuel tank capacity | L (gal) | 572 (151) | | | |
| Hose length | m (ft) | 670 (2200) | | | |
| Hose loops | qty | 2 | | | |
| HTF capacity | L (gal) | 360 (95) | | | |
| HTF Pump | L/hr (gph) | 2 X 1003 (2 X 265) | | | |
| Burner make/model | — | Beckett / AFG GH106 | | | |
| Burner nozzle | gph X deg | 1.35 70° B | | | |
| Fuel pressure | bar (psi) | 12.4 (180) | | | |
| Fuel input | kW/hr (BTU)/hr | 74 252,000 | | | |
| Heat output | kW/hr (BTU)/hr | 65 220,000 | | | |
| Heater efficiency | % | 87 | | | |
| Run time (up to) | hr | 130 | | | |
| Hose pressure | bar (psi) | 4.8–6.2 (70–90) | | | |
| Standard thaw capacity | m ² (ft ²) | 204–409 (2200–4400) | | | |
| Accelerated thaw capacity | m ² (ft ²) | 409 (4,400) | | | |
| Standard cure capacity | m ² (ft ²) | 409 (4,400) | | | |
| Expanded cure capacity | m ² (ft ²) | 1,226 (13,200) | | | |
| Standard frost prevention | m ² (ft ²) | 836 (9,000) | | | |
| Expanded frost prevention | m ² (ft ²) | 1,839 (19,800) | | | |
| Air heat capacity | m ³ (ft ³) | 10,194 (360,000) | | | |

9.2 E 3000ES

| E 3000ES | Units | Item No. 0620967 | Item No. 0620968 |
|---------------------------|-----------------------------------|-----------------------|---------------------|
| Weight, no fuel | kg (lb) | 2250 (4960) | 2250 (4960) |
| Weight, full fuel | kg (lb) | 2597 (5725) | 2597 (5725) |
| Generator weight | kg (lb) | n/a | 238 (525) |
| Fuel tank capacity | L (gal) | 115 (435) | |
| Hose length | m (ft) | 914 (3000) | |
| Hose loops | qty | 2 | |
| HTF capacity | L (gal) | 435 (115) | |
| HTF Pump | L/hr (gph) | 2 X 1003 (2 X 265) | |
| Burner make/model | — | Beckett / AFG GH106 | |
| Burner nozzle | gph X deg | 1.35 70° B | |
| Fuel pressure | bar (psi) | 12.4 (180) | |
| Fuel input | kW/hr (BTU)/hr | 74 252,000 | |
| Heat output | kW/hr (BTU)/hr | 65 220,000 | |
| Heater efficiency | % | 87 | |
| Run time (up to) | hrs | 82 | |
| Hose pressure | bar (psi) | 7.5 (110) | |
| Standard thaw capacity | m ² (ft ²) | 278–557 (3,000–6,000) | |
| Accelerated thaw capacity | m ² (ft ²) | 557 (6,000) | |
| Standard cure capacity | m ² (ft ²) | 557 (6,000) | |
| Expanded cure capacity | m ² (ft ²) | 1,115 (12,000) | |
| Standard frost prevention | m ² (ft ²) | 836 (9,000) | |
| Expanded frost prevention | m ² (ft ²) | 1,672 (18,000) | |
| Air heat capacity | m ³ (ft ³) | 10,194 (360,000) | |

9.3 Trailer

| Item Number Model | | E 2200 | E 3000ES |
|---------------------------------------|--------------|-----------------|---------------------------|
| Axle rating | kg (lb) | 2722 (6000) | 3175 (7000) |
| Wheel diameter | mm (in.) | 381 (15) | 406 (16) |
| Wheel code | – | Y701500 16x6K | 16x6K |
| Wheel rating | kg (lb) | 1701 (3750) | 1701 (3750) |
| Tire code | – | ST235/80R16 LRD | LT 235/85R16 |
| Tire pressure | bar (psi) | 4,5 (65) | 7,5 (110) |
| Lug nut torque | Nm (ft.lbs.) | 149 (110) | 149 (110) |
| GVWR (Gross Vehicle Weight Rating) | kg (lb) | 2878 (6345) | 2994 (6600) |
| Hitch type | – | 2-in. Ball | 2-5/16 in. ball or pintle |
| Brake type | – | Electric | |
| Maximum towing speed | km/h (mph) | 72 (45) | 72 (45) |

9.4 Dimensions

cm (in.)

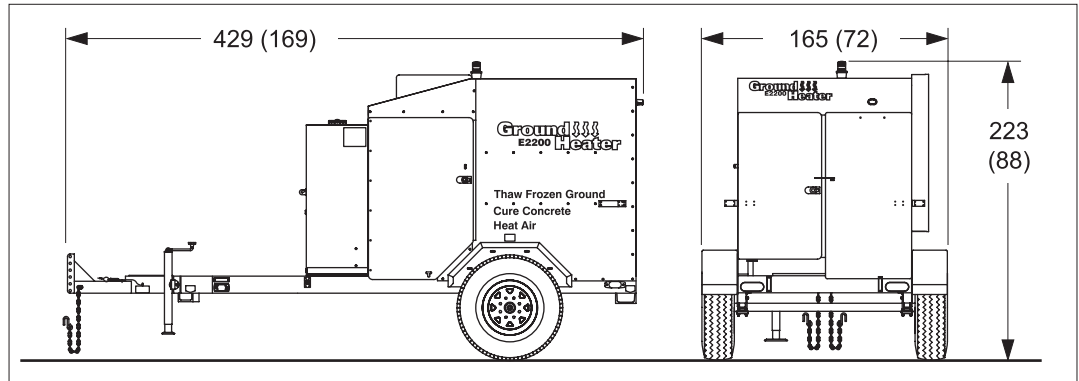

ghi_gr005645

MSDS: Dowfrost™ HD 50

MSDS: Dowfrost™ HD 50



Material Safety Data Sheet The Dow Chemical Company

Product Name: DOWFROST* HD 50 Heat Transfer Fluid, Dyed

Issue Date: 12/10/2007

Print Date: 01 Sep 2010

The Dow Chemical Company encourages and expects you to read and understand the entire (M)SDS, as there is important information throughout the document. We expect you to follow the precautions identified in this document unless your use conditions would necessitate other appropriate methods or actions.

1. Product and Company Identification

Product Name

DOWFROST* HD 50 Heat Transfer Fluid, Dyed

COMPANY IDENTIFICATION

The Dow Chemical Company
2030 Willard H. Dow Center
Midland, MI 48674
USA

Customer Information Number:

800-258-2436

EMERGENCY TELEPHONE NUMBER

24-Hour Emergency Contact:

989-636-4400

Local Emergency Contact:

989-636-4400

2. Hazards Identification

Emergency Overview

Color: Yellow

Physical State: Liquid

Odor: Characteristic

Hazards of product:

No significant immediate hazards for emergency response are known.

OSHA Hazard Communication Standard

This product is not a "Hazardous Chemical" as defined by the OSHA Hazard Communication Standard, 29 CFR 1910.1200.

Potential Health Effects

Eye Contact: May cause slight temporary eye irritation. Corneal injury is unlikely.

Skin Contact: Prolonged contact is essentially nonirritating to skin. Repeated contact may cause flaking and softening of skin.

Skin Absorption: Prolonged skin contact is unlikely to result in absorption of harmful amounts.

Inhalation: At room temperature, exposure to vapor is minimal due to low volatility. Mist may cause irritation of upper respiratory tract (nose and throat).

®(TM)*Trademark of The Dow Chemical Company ("Dow") or an affiliated company of Dow

Product Name: DOWFROST* HD 50 Heat Transfer Fluid, Dyed

Issue Date: 12/10/2007

Ingestion: Very low toxicity if swallowed. Harmful effects not anticipated from swallowing small amounts.

Effects of Repeated Exposure: In rare cases, repeated excessive exposure to propylene glycol may cause central nervous system effects.

3. Composition Information

| Component | CAS # | Amount |
|--------------------------------|-----------|-------------------|
| Propylene glycol | 57-55-6 | > 48.0 - < 54.0 % |
| Water | 7732-18-5 | < 50.0 % |
| Dipotassium hydrogen phosphate | 7758-11-4 | < 3.0 % |

4. First-aid measures

Eye Contact: Flush eyes thoroughly with water for several minutes. Remove contact lenses after the initial 1-2 minutes and continue flushing for several additional minutes. If effects occur, consult a physician, preferably an ophthalmologist.

Skin Contact: Wash skin with plenty of water.

Inhalation: Move person to fresh air; if effects occur, consult a physician.

Ingestion: No emergency medical treatment necessary.

Notes to Physician: No specific antidote. Treatment of exposure should be directed at the control of symptoms and the clinical condition of the patient.

5. Fire Fighting Measures

Extinguishing Media: To extinguish combustible residues of this product use water fog, carbon dioxide, dry chemical or foam.

Fire Fighting Procedures: Keep people away. Isolate fire and deny unnecessary entry. Use water spray to cool fire exposed containers and fire affected zone until fire is out and danger of reignition has passed. To extinguish combustible residues of this product use water fog, carbon dioxide, dry chemical or foam.

Special Protective Equipment for Firefighters: Wear positive-pressure self-contained breathing apparatus (SCBA) and protective fire fighting clothing (includes fire fighting helmet, coat, trousers, boots, and gloves). If protective equipment is not available or not used, fight fire from a protected location or safe distance.

Unusual Fire and Explosion Hazards: This material will not burn until the water has evaporated. Residue can burn.

Hazardous Combustion Products: Under fire conditions some components of this product may decompose. The smoke may contain unidentified toxic and/or irritating compounds. Combustion products may include and are not limited to: Carbon monoxide. Carbon dioxide.

6. Accidental Release Measures

Steps to be Taken if Material is Released or Spilled: Small spills: Absorb with materials such as: Cat litter. Sawdust. Vermiculite. Zorb-all®. Collect in suitable and properly labeled containers. Large spills: Dike area to contain spill. See Section 13, Disposal Considerations, for additional information.

Personal Precautions: Keep unnecessary and unprotected personnel from entering the area. Use appropriate safety equipment. For additional information, refer to Section 8, Exposure Controls and Personal Protection.

Environmental Precautions: Prevent from entering into soil, ditches, sewers, waterways and/or groundwater. See Section 12, Ecological Information.

MSDS: Dowfrost™ HD 50

Product Name: DOWFROST* HD 50 Heat Transfer Fluid, Dyed

Issue Date: 12/10/2007

7. Handling and Storage

Handling

General Handling: No special precautions required. Spills of these organic materials on hot fibrous insulations may lead to lowering of the autoignition temperatures possibly resulting in spontaneous combustion. See Section 8, EXPOSURE CONTROLS AND PERSONAL PROTECTION.

Storage

Do not store in: Galvanized steel. Opened or unlabeled containers. Store in the following material(s): Carbon steel. Stainless steel. Store in original unopened container. See Section 10 for more specific information. Additional storage and handling information on this product may be obtained by calling your Dow sales or customer service contact.

8. Exposure Controls / Personal Protection

Exposure Limits

| Component | List | Type | Value |
|------------------|------|-----------------|----------|
| Propylene glycol | WEEL | TWA Aerosol. | 10 mg/m3 |

Personal Protection

Eye/Face Protection: Use safety glasses.

Skin Protection: Wear clean, body-covering clothing.

Hand protection: Use gloves chemically resistant to this material when prolonged or frequently repeated contact could occur. Examples of preferred glove barrier materials include: Butyl rubber. Natural rubber ("latex"). Neoprene. Nitrile/butadiene rubber ("nitrile" or "NBR"). Polyethylene. Ethyl vinyl alcohol laminate ("EVAL"). Polyvinyl alcohol ("PVA"). Polyvinyl chloride ("PVC" or "vinyl"). NOTICE: The selection of a specific glove for a particular application and duration of use in a workplace should also take into account all relevant workplace factors such as, but not limited to: Other chemicals which may be handled, physical requirements (cut/puncture protection, dexterity, thermal protection), potential body reactions to glove materials, as well as the instructions/specifications provided by the glove supplier.

Respiratory Protection: Respiratory protection should be worn when there is a potential to exceed the exposure limit requirements or guidelines. If there are no applicable exposure limit requirements or guidelines, wear respiratory protection when adverse effects, such as respiratory irritation or discomfort have been experienced, or where indicated by your risk assessment process. In misty atmospheres, use an approved particulate respirator. The following should be effective types of air-purifying respirators: Organic vapor cartridge with a particulate pre-filter.

Ingestion: Use good personal hygiene. Do not consume or store food in the work area. Wash hands before smoking or eating.

Engineering Controls

Ventilation: Use local exhaust ventilation, or other engineering controls to maintain airborne levels below exposure limit requirements or guidelines. If there are no applicable exposure limit requirements or guidelines, general ventilation should be sufficient for most operations. Local exhaust ventilation may be necessary for some operations.

9. Physical and Chemical Properties

| | |
|--------------------------|--|
| Physical State | Liquid |
| Color | Yellow |
| Odor | Characteristic |
| Flash Point - Closed Cup | Not applicable, water boils off |
| Flammable Limits In Air | Lower: 2.6 %(V) <i>Literature</i> Propylene glycol |

Product Name: DOWFROST* HD 50 Heat Transfer Fluid, Dyed

Issue Date: 12/10/2007

| | |
|--|--|
| Autoignition Temperature | Upper: 12.5 %(V) <i>Literature</i> Propylene glycol 371 °C (700 °F) <i>Literature</i> Propylene glycol |
| Vapor Pressure | 15.5 mmHg @ 20 °C <i>Literature</i> |
| Boiling Point (760 mmHg) | 104 °C (219 °F) <i>Literature</i> . |
| Vapor Density (air = 1) | >1.0 <i>Literature</i> |
| Specific Gravity (H2O = 1) | 1.06 20 °C/20 °C <i>Literature</i> |
| Freezing Point | -33.8 °C (-28.8 °F) <i>Literature</i> |
| Melting Point | Not applicable to liquids |
| Solubility in Water (by weight) | 100 % <i>Literature</i> |
| pH | 9.5 <i>Literature</i> |
| Kinematic Viscosity | 6.3 cSt <i>Literature</i> |

10. Stability and Reactivity

Stability/Instability

Thermally stable at recommended temperatures and pressures.

Conditions to Avoid: Some components of this product can decompose at elevated temperatures. Generation of gas during decomposition can cause pressure in closed systems.

Incompatible Materials: Avoid contact with: Strong acids. Strong bases. Strong oxidizers.

Hazardous Polymerization

Will not occur.

Thermal Decomposition

Decomposition products depend upon temperature, air supply and the presence of other materials.

11. Toxicological Information

Acute Toxicity

Ingestion

LD50, Rat, female 20,300 mg/kg

Skin Absorption

For similar material(s): LD50, Rabbit > 10,000 mg/kg

Sensitization

Skin

For the major component(s): Did not cause allergic skin reactions when tested in humans.

Repeated Dose Toxicity

In rare cases, repeated excessive exposure to propylene glycol may cause central nervous system effects.

Chronic Toxicity and Carcinogenicity

Similar formulations did not cause cancer in laboratory animals.

Developmental Toxicity

For the major component(s): Did not cause birth defects or any other fetal effects in laboratory animals.

Reproductive Toxicity

For the major component(s): In animal studies, did not interfere with reproduction. In animal studies, did not interfere with fertility.

Genetic Toxicology

In vitro genetic toxicity studies were negative. For the major component(s): Animal genetic toxicity studies were negative.

Product Name: DOWFROST* HD 50 Heat Transfer Fluid, Dyed

Issue Date: 12/10/2007

12. Ecological Information

CHEMICAL FATE

Movement & Partitioning

For the major component(s): Bioconcentration potential is low (BCF less than 100 or log Pow less than 3). Potential for mobility in soil is very high (Koc between 0 and 50).

Persistence and Degradability

For the major component(s): Material is readily biodegradable. Passes OECD test(s) for ready biodegradability.

ECOTOXICITY

For the major component(s): Material is practically non-toxic to aquatic organisms on an acute basis (LC50/EC50 >100 mg/L in the most sensitive species tested).

13. Disposal Considerations

DO NOT DUMP INTO ANY SEWERS, ON THE GROUND, OR INTO ANY BODY OF WATER. All disposal practices must be in compliance with all Federal, State/Provincial and local laws and regulations. Regulations may vary in different locations. Waste characterizations and compliance with applicable laws are the responsibility solely of the waste generator. DOW HAS NO CONTROL OVER THE MANAGEMENT PRACTICES OR MANUFACTURING PROCESSES OF PARTIES HANDLING OR USING THIS MATERIAL. THE INFORMATION PRESENTED HERE PERTAINS ONLY TO THE PRODUCT AS SHIPPED IN ITS INTENDED CONDITION AS DESCRIBED IN MSDS SECTION: Composition Information. FOR UNUSED & UNCONTAMINATED PRODUCT, the preferred options include sending to a licensed, permitted: Recycler. Reclaimer. Incinerator or other thermal destruction device. As a service to its customers, Dow can provide names of information resources to help identify waste management companies and other facilities which recycle, reprocess or manage chemicals or plastics, and that manage used drums. Telephone Dow's Customer Information Group at 1-800-258-2436 or 1-989-832-1556 (U.S.), or 1-800-331-6451 (Canada) for further details.

14. Transport Information

DOT Non-Bulk

NOT REGULATED

DOT Bulk

NOT REGULATED

IMDG

NOT REGULATED

ICAO/IATA

NOT REGULATED

This information is not intended to convey all specific regulatory or operational requirements/information relating to this product. Additional transportation system information can be obtained through an authorized sales or customer service representative. It is the responsibility of the transporting organization to follow all applicable laws, regulations and rules relating to the transportation of the material.

Product Name: DOWFROST* HD 50 Heat Transfer Fluid, Dyed

Issue Date: 12/10/2007

15. Regulatory Information

OSHA Hazard Communication Standard

This product is not a "Hazardous Chemical" as defined by the OSHA Hazard Communication Standard, 29 CFR 1910.1200.

Superfund Amendments and Reauthorization Act of 1986 Title III (Emergency Planning and Community Right-to-Know Act of 1986) Sections 311 and 312

| | |
|--|----|
| Immediate (Acute) Health Hazard | No |
| Delayed (Chronic) Health Hazard | No |
| Fire Hazard | No |
| Reactive Hazard | No |
| Sudden Release of Pressure Hazard | No |

Superfund Amendments and Reauthorization Act of 1986 Title III (Emergency Planning and Community Right-to-Know Act of 1986) Section 313

To the best of our knowledge, this product does not contain chemicals at levels which require reporting under this statute.

Pennsylvania (Worker and Community Right-To-Know Act): Pennsylvania Hazardous Substances List and/or Pennsylvania Environmental Hazardous Substance List:

The following product components are cited in the Pennsylvania Hazardous Substance List and/or the Pennsylvania Environmental Substance List, and are present at levels which require reporting.

| Component | CAS # | Amount |
|------------------|--------------|-------------------|
| Propylene glycol | 57-55-6 | > 48.0 - < 54.0 % |

Pennsylvania (Worker and Community Right-To-Know Act): Pennsylvania Special Hazardous Substances List:

To the best of our knowledge, this product does not contain chemicals at levels which require reporting under this statute.

California Proposition 65 (Safe Drinking Water and Toxic Enforcement Act of 1986)

This product contains no listed substances known to the State of California to cause cancer, birth defects or other reproductive harm, at levels which would require a warning under the statute.

Toxic Substances Control Act (TSCA)

All components of this product are on the TSCA Inventory or are exempt from TSCA Inventory requirements under 40 CFR 720.30

CEPA - Domestic Substances List (DSL)

This product contains one or more substances which are not listed on the Canadian Domestic Substances List (DSL). Contact your Dow representative for more information.

16. Other Information

Hazard Rating System

| | | | |
|-------------|---------------|-------------|-------------------|
| NFPA | Health | Fire | Reactivity |
| 0 | 0 | 0 | 0 |

Recommended Uses and Restrictions

Intended as a heat transfer fluid for closed-loop systems. Dow recommends that you use this product in a manner consistent with the listed use. If your intended use is not consistent with Dow's stated use, please contact Dow's Customer Information Group.

Revision

Identification Number: 50551 / 1001 / Issue Date 12/10/2007 / Version: 3.0

MSDS: Dowfrost™ HD 50

Product Name: DOWFROST* HD 50 Heat Transfer Fluid, Dyed

Issue Date: 12/10/2007

Most recent revision(s) are noted by the bold, double bars in left-hand margin throughout this document.

Legend

| | |
|--------------|---|
| N/A | Not available |
| W/W | Weight/Weight |
| OEL | Occupational Exposure Limit |
| STEL | Short Term Exposure Limit |
| TWA | Time Weighted Average |
| ACGIH | American Conference of Governmental Industrial Hygienists, Inc. |
| DOW IHG | Dow Industrial Hygiene Guideline |
| WEEL | Workplace Environmental Exposure Level |
| HAZ DES | Hazard Designation |
| Action Level | A value set by OSHA that is lower than the PEL which will trigger the need for activities such as exposure monitoring and medical surveillance if exceeded. |

The Dow Chemical Company urges each customer or recipient of this (M)SDS to study it carefully and consult appropriate expertise, as necessary or appropriate, to become aware of and understand the data contained in this (M)SDS and any hazards associated with the product. The information herein is provided in good faith and believed to be accurate as of the effective date shown above. However, no warranty, express or implied, is given. Regulatory requirements are subject to change and may differ between various locations. It is the buyer's/user's responsibility to ensure that his activities comply with all federal, state, provincial or local laws. The information presented here pertains only to the product as shipped. Since conditions for use of the product are not under the control of the manufacturer, it is the buyer's/user's duty to determine the conditions necessary for the safe use of this product. Due to the proliferation of sources for information such as manufacturer-specific (M)SDSs, we are not and cannot be responsible for (M)SDSs obtained from any source other than ourselves. If you have obtained an (M)SDS from another source or if you are not sure that the (M)SDS you have is current, please contact us for the most current version.

Fuji Temperature Controller

Fuji Temperature Controller Hysteresis (differential) Adjusting

FUJI PXR-4 HYSTERESIS (DIFFERENTIAL) ADJUSTING

1 PRESS AND HOLD, RELEASE WHEN **LoC** IS DISPLAYED

2 TAP ONCE, THE GREEN NUMBER WILL BEGIN FLASHING

3 TAP TWICE, THE VALUE OF THE GREEN NUMBER SHOULD READ ZERO

4 PRESS & HOLD UNTIL THE NORMAL DISPLAY APPEARS

5 PRESS AND HOLD, RELEASE WHEN **P** IS DISPLAYED

6 TAP REPEATEDLY UNTIL **HYS** IS DISPLAYED

7 TAP ONCE, THE GREEN NUMBERS WILL BEGIN FLASHING

8 TAP REPEATEDLY UNTIL THE VALUE CORRESPONDS TO THE GUIDE BELOW

9 PRESS & HOLD UNTIL THE NORMAL DISPLAY APPEARS

1 PRESS AND HOLD, RELEASE WHEN **LoC** IS DISPLAYED

2 TAP ONCE, THE GREEN NUMBER WILL BEGIN FLASHING

3 TAP TWICE, THE VALUE OF THE GREEN NUMBER SHOULD READ TWO

4 PRESS & HOLD UNTIL THE NORMAL DISPLAY APPEARS

RECOMMENDED HYSTERESIS (DIFFERENTIAL) VALUES BY MODEL

- E1100, E700M, E2200, E3000, Pureheat = 10
- Arctic Bear XHD & HD models = 5

Fuji Temperature Controller

Fuji Temperature Controller Low Temperature Limit Adjusting

FUJI PXR-4 LOW TEMPERATURE LIMIT ADJUSTING

- 1** PRESS AND HOLD, RELEASE WHEN **LoC** IS DISPLAYED

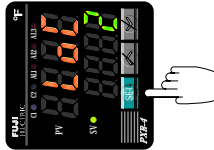

- 2** TAP ONCE, THE GREEN NUMBER WILL BEGIN FLASHING

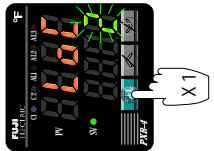

- 3** TAP TWICE, THE VALUE OF THE GREEN NUMBER SHOULD READ ZERO

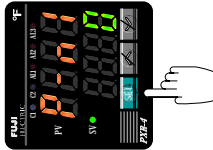

- 4** PRESS & HOLD UNTIL THE NORMAL DISPLAY APPEARS

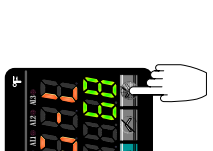

- 5** PRESS AND HOLD, RELEASE WHEN **P-r 1** IS DISPLAYED



- 6** TAP REPEATEDLY UNTIL **SV-L** IS DISPLAYED

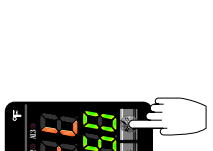

- 7** TAP ONCE, THE GREEN NUMBERS WILL BEGIN FLASHING

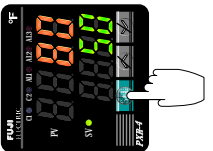

- 8** TAP REPEATEDLY UNTIL THE VALUE CORRESPONDS TO THE GUIDE BELOW

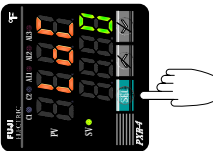

- 9** PRESS & HOLD UNTIL THE NORMAL DISPLAY APPEARS

- 10** PRESS AND HOLD, RELEASE WHEN **LoC** IS DISPLAYED

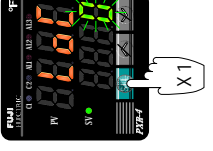
- 11** TAP ONCE, THE GREEN NUMBER WILL BEGIN FLASHING

- 12** TAP TWICE, THE VALUE OF THE GREEN NUMBER SHOULD READ TWO

- 13** PRESS & HOLD UNTIL THE NORMAL DISPLAY APPEARS



LOW TEMPERATURE LIMIT VALUES BY MODEL

E1100, E700M, E2200, E3000, E3000, Pureheat = 50
Arctic Bear XHD & HD models = 50

Fuji Temperature Controller High Temperature Limit Adjusting

FUJI PXR-4 HIGH TEMPERATURE LIMIT ADJUSTING

- 1** PRESS AND HOLD, RELEASE WHEN **LoC** IS DISPLAYED

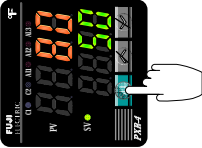

- 2** TAP ONCE, THE GREEN NUMBER WILL BEGIN FLASHING

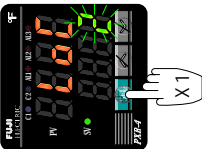

- 3** TAP TWICE, THE VALUE OF THE GREEN NUMBER SHOULD READ ZERO



- 4** PRESS & HOLD UNTIL THE NORMAL DISPLAY APPEARS

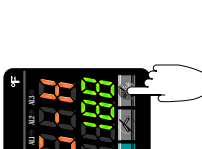

- 5** PRESS AND HOLD, RELEASE WHEN **P-n 1** IS DISPLAYED



- 6** TAP REPEATEDLY UNTIL **SV-H** IS DISPLAYED



- 7** TAP ONCE, THE GREEN NUMBERS WILL BEGIN FLASHING

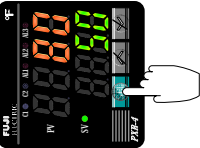

- 8** TAP REPEATEDLY UNTIL THE VALUE CORRESPONDS TO THE GUIDE BELOW

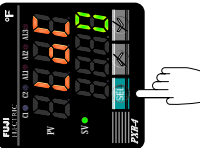

- 9** PRESS & HOLD UNTIL THE NORMAL DISPLAY APPEARS

- 10** PRESS AND HOLD, RELEASE WHEN **LoC** IS DISPLAYED

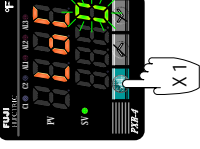
- 11** TAP ONCE, THE GREEN NUMBER WILL BEGIN FLASHING

- 12** TAP TWICE, THE VALUE OF THE GREEN NUMBER SHOULD READ TWO

- 13** PRESS & HOLD UNTIL THE NORMAL DISPLAY APPEARS



HIGH TEMPERATURE LIMIT VALUES BY MODEL

E1100, E700M, E2200, S3000, E3000, Pureheat = 180
Arctic Bear XHD & HD models = 210

10 Schematics



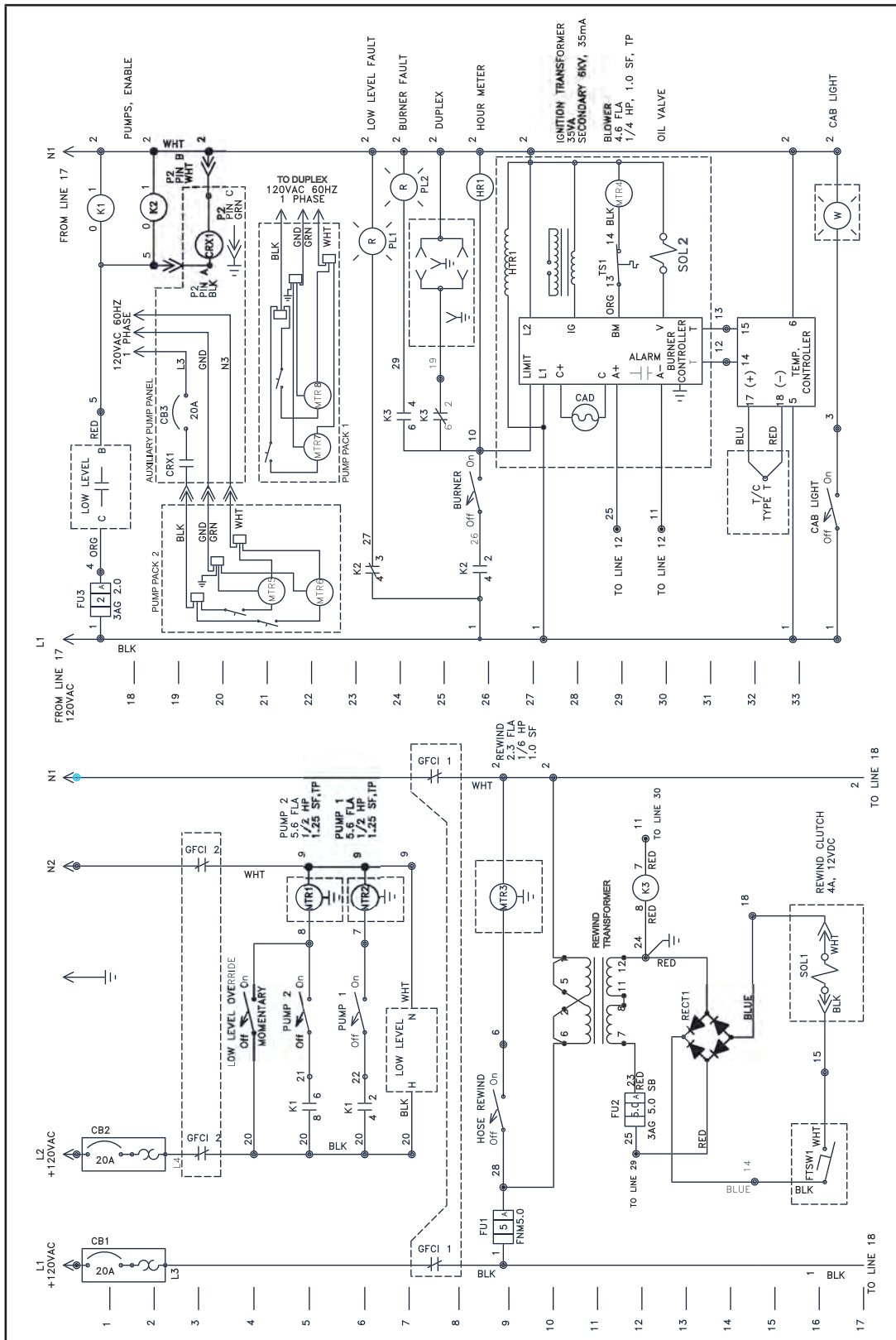





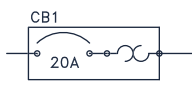

10.1 Electrical Schematic



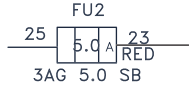
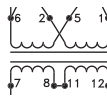



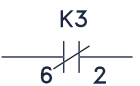



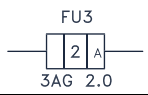

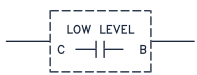



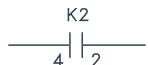





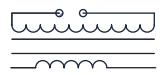

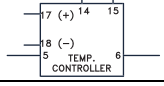

ghi_gr005547

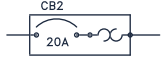
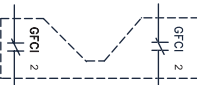
10.2 Electrical Schematic Components

Use the following table of symbols for the schematics found throughout this chapter.

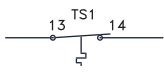
| Symbol | Ref | Description |
|---|-------------|--|
|  | CB1 | Circuit breaker 1 |
|  | GFCI 1 | Ground Fault Circuit Interrupt 1 |
|  | FU1 | Fuse 1 |
|  | HOSE REWIND | Hose rewind Off/On switch |
|  | MTR | Rewind motor Pump motor Burner motor |
|  | FU2 | Fuse 2 |
|  | n/a | Rewind transformer |
| n/a | n/a | To line 30 |
| n/a | n/a | To line 29 |
|  | RECT1 | Rectifier |
|  | FTSW1 | Foot switch 1 |
|  | SOL1 | Solenoid 1 (rewind clutch) |
| n/a | n/a | To line 18 |
| n/a | n/a | From line 17 |
|  | K3 | Relay coil (K3) |
|  | K3 | Relay normally closed contacts (K3) |
|  | K3 | Relay normally open contacts (K3) |

| Symbol | Ref | Description |
|---|---------------|---|
|  | FU3 | Fuse 3 |
|  | LOW LEVEL | Low-level shut down device power connection terminals |
|  | LOW LEVEL | Low-level shut down device normally open contacts |
| n/a | n/a | Pumps, enable |
| n/a | n/a | Pump pack |
|  | K1 | Relay coil (K1) |
|  | K1 | Relay normally open contacts (K1) |
|  | K2 | Relay coil (K2) |
|  | K2 | Relay normally closed contacts (K2) |
|  | K2 | Relay normally open contacts (K2) |
| n/a | n/a | 1 phase |
|  | CRX1 | Relay coil (CRX1) |
|  | CRX1 | Relay normally open contacts (CRX1) |
|  | PL1 | Pilot light 1 Low level fault |
|  | PL2 | Pilot light 2 Burner fault |
|  | DUPLEX | Duplex receptacle |
|  | HOUR METER | Hour meter |
|  | n/a | Ignition transformer |
| n/a | n/a | Blower |
| n/a | n/a | Limit |
| n/a | n/a | Alarm |
| n/a | n/a | Burner controller (primary control) |

| Symbol | Ref | Description |
|---|------------------------------------|--|
|  | SOL 2 | Solenoid 2 (Oil valve) |
|  | T/C type T | Thermocouple Type T |
|  | TEMP. CONTROLLER | Temp. (temperature) controller |
|  | n/a | Cab light |
|  | CAB LIGHT | Cab light Off/On switch |
|  | CB 2 | Circuit breaker 2 |
|  | GFCI 2 | Ground Fault Circuit Interrupt 2 |
|  | PUMP 2 | Pump 2 Off/On switch |
|  | PUMP 1 | Pump 1 Off/On switch |
|  | GND | Ground |
|  | TS1 | Thermal switch 1 (snap disc) |
|  | HTR1 | Heater (fuel prewarmer) |
|  | CAD | Cad cell |
|  | LOW LEVEL OVERRIDE MOMENTARY | Low-level shut down device momentary override Off/On switch. |
| n/a | n/a | Auxilliary pump panel |
|  | BURNER | Burner Off/On switch |
| n/a | REWIND | Rewind |

10.3 Burner System Circuit

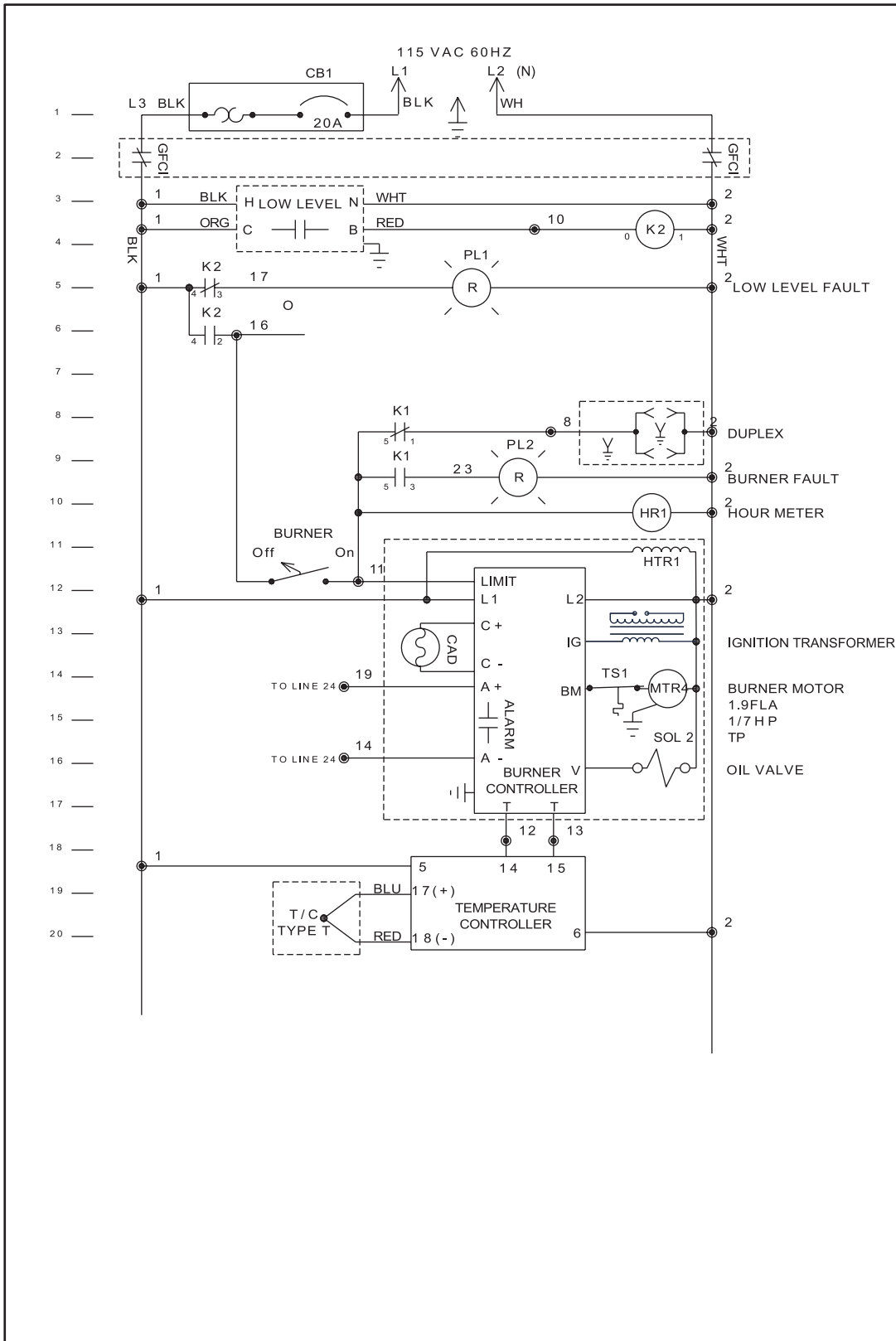

ghi_gr005711

10.4 Circulation System Circuit

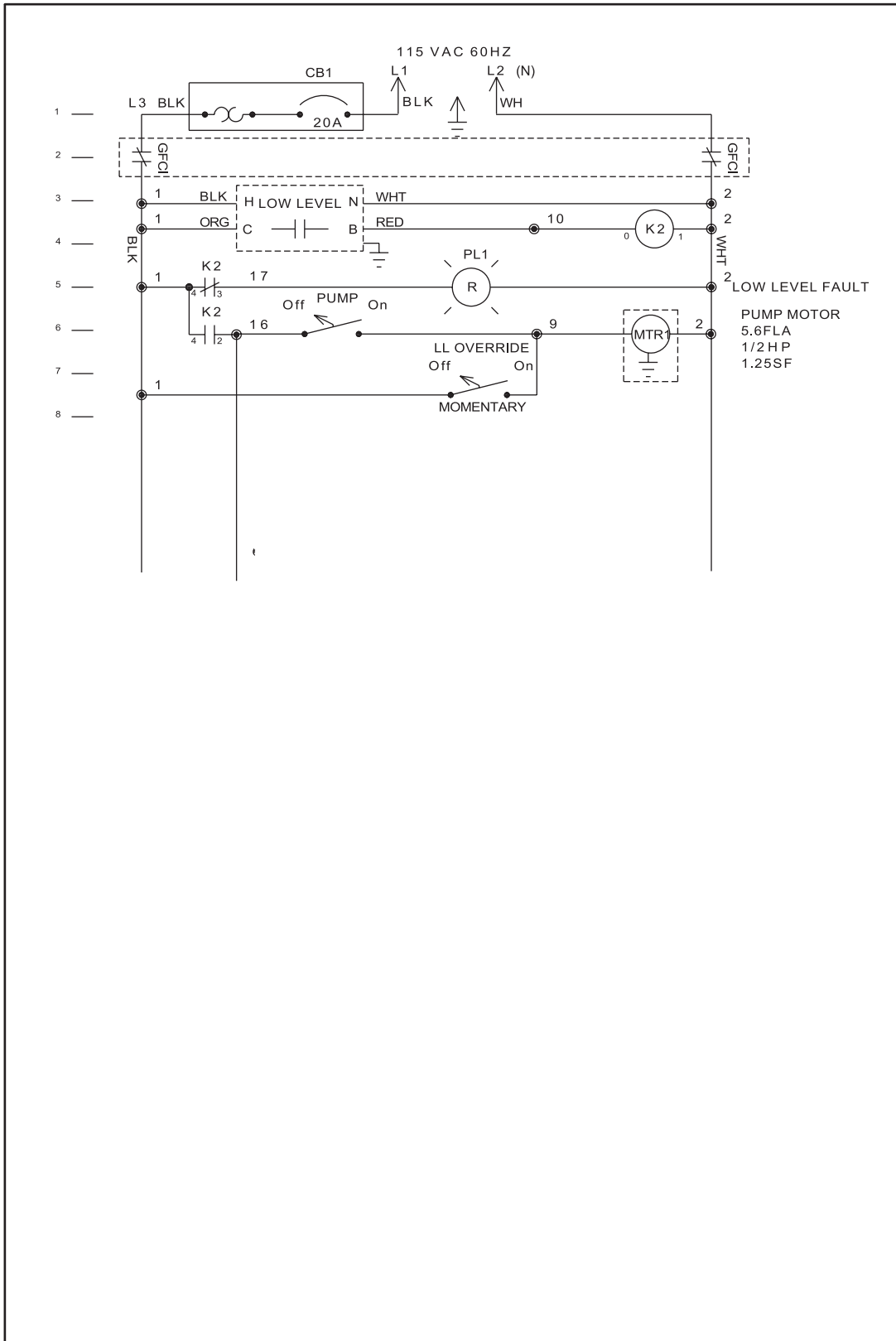

ghi_gr005662

10.5 Rewind System Circuit

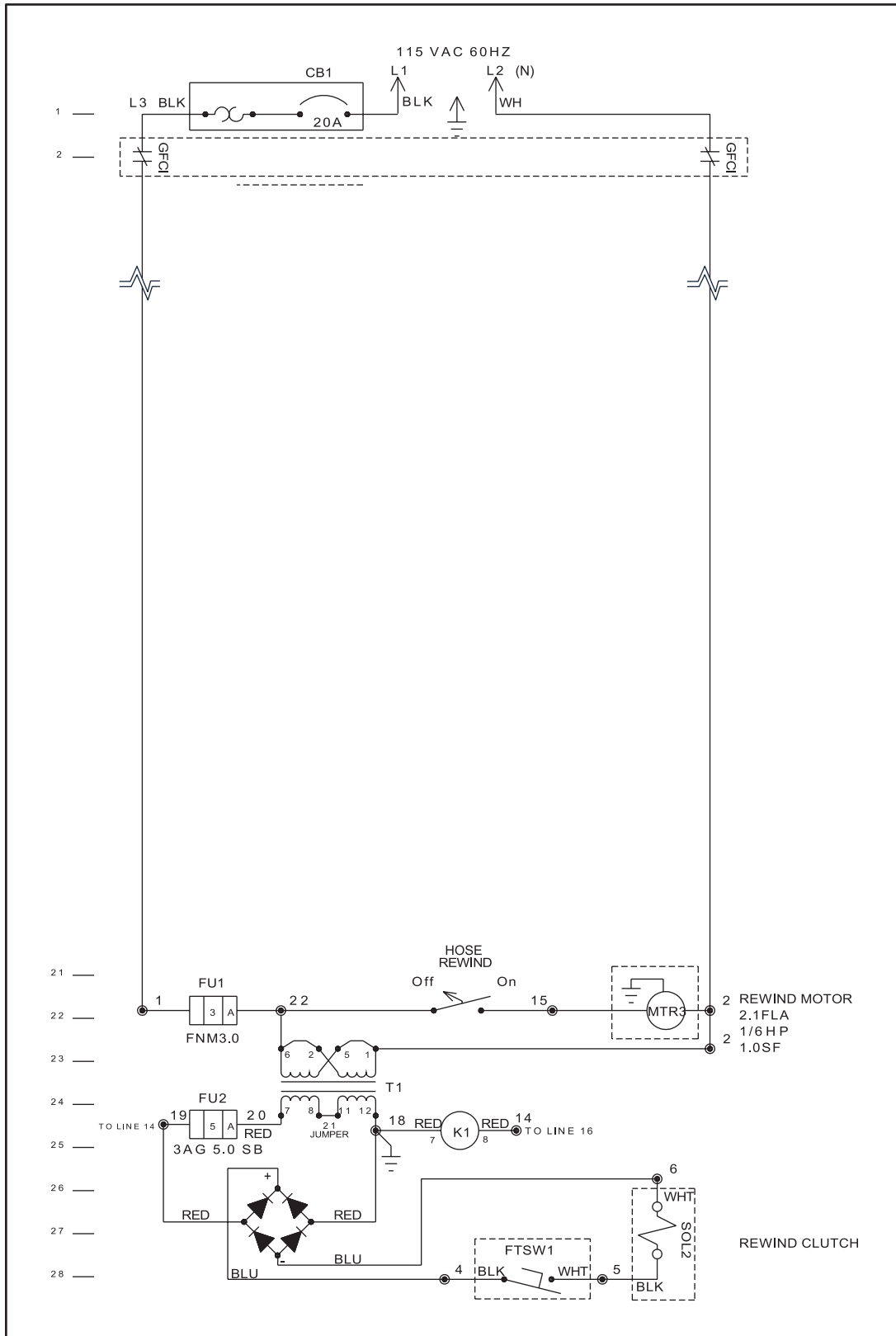

ghi_gr005710

